

# R

# REINHEIMER R

The specialist for Retreaders, Vulcanizers and Tyre Dealers



THE PROFESSIONAL'S CHOICE  
FOR TYRE REPAIR  
SINCE **1919**





Tyre repair 1928 in Hamburg



Tyre repair training 1930

*When innovation meets enthusiasm then perspectives arise!*



Christoph Goerke / General Manager

Timo Goerke / Sales Manager



**THE PROFESSIONAL'S CHOICE  
FOR TYRE REPAIR  
SINCE 1919**



**SEITE 1/ 01 - 1/ 15**



**SEITE 2/ 01 - 2/ 14**



**SEITE 3/ 01 - 3/ 10**



**SEITE 4 / 01 - 4 / 05**



**SEITE 5 / 01 - 5 / 08**



**SEITE 6 / 01 - 6 / 02**



**SEITE 7/ 01 - 7/ 04**



**2 Strong brands!**

Our products are manufactured according to ISO 9001.

To ensure quality, we work together with the German TÜV



**REINHEIMER GMBH  
Fachhandel & Co KG  
Borgwardstrasse 10-12  
D-21365 Adendorf / GERMANY**

**Tel: +49 (0) 4131 981 661  
Fax: +49 (0) 4131 981 663  
www.rei-pa.com**







**NEU!!**

VERSACURE FROM 20°C - 160°C

**Radial Repair Patches Series „A“.**

Due to a newly developed cushion gum this patch can be used for cold and hot vulcanisation from 95°C to 165°C. Patches of Series “A” don’t have to be cushioned for hot vulcanisation with a second layer of gum!!

**Hot Vulcanisation with HL-Hot Cement, black.**

Spray Cements, also those without Trichloroethylene, as they are used by retreaders, are permitted by the manufacturer. Readily installed patches coated with HL-Cement can be stored for several days below 80°C prior to curing, without fear of a chemical reaction beforehand.

**Handling**

**Cold**



**MAXI BOND CEMENT**  
Solutions page 1/09

**Hot**



**HL HEIZLÖSUNG**  
Solutions page 1/10



Reinforced with Aramit

Cat No	Discription	Compare	Size/mm	Plies	Unit/Box
067141	APX 10	110TL	70*50	1	20
067142	APX 12	112TL	105*60	1	10
067143	APX 14	114TL	120*75	1	10

Cat No	Discription	Compare	Size/mm	Plies	Unit/Box
067144	APX 20	120TL	100*75	2	10
067145	APX 22	122TL	155*75	2	10
067146	APX 24	124TL	210*75	2	10
067147	APX 40	140TL	190*100	3	10
067148	APX 42	142TL	255*130	4	5
067152	APX 26	126TL	260*75	3	10
067153	APX 28	128TL	330*75	3	10
067139	APX 25	125TL	115*120	3	10
067140	APX 35	135TL	175*125	4	10

Cat No	Discription	Compare	Size/mm	Plies	Unit/Box
067149	APX 44	144TL	330*130	4	5
067151	APX 46	146TL	415*150	4	5
067150	APX 45	145TL	230*180	4	10

Cat No	Discription	Compare	Size/mm	Plies	Unit/Box
067180	APX 80	180TL	205*140	2	5
067282	APX 82	182TL	270*190	2	5
067284	APX 84	184TL	285*215	3	5
067286	APX 86	186TL	340*245	3	5

Cat No	Discription	Compare	Size/mm	Plies	Unit/Box
067170	APX 50	150TL	565*205	5	6
067171	APX 52	152TL	570*255	5	6
067172	APX 56	156TL	735*270	7	3
067173	APX 60	160TL	1015*270	7	3

\* Only Crown repair



TYRE REPAIR CHART

This is an internationally valid repair chart. The figures refer to the extent of damage. Always make a general check to ensure that the tyre can be repaired. Examine the complete tyre for further hidden damages. The maximum limits for the repairable injuries indicated must not be exceeded. Repair limits that exist in individual countries have not been taken into consideration in this chart. When referring to this repair chart, the user is obliged to assess whether the indicated safety limits should be increased, by taking into account these regulations and local road, load and operating conditions. Follow the corresponding fitting and processing instructions when carrying out repairs.



PATCH SIZE	L	W	L	W	C
Q	10	12	6	10	10
Q	APX 14	35	20	20	20
S/T	APX 10	12	6	8	8
S/T	APX 12	30	15	12	12
H/V	APX 10	6	6	6	6
ZR	APX 10			3	3



PATCH SIZE	L	W	L	W	C
APX 20	20	20	30	20	10
APX 80	70	50	60	40	25
APX 80	50	70	60	40	25
APX 82	100	70	90	70	45
APX 82	70	120	90	70	45
APX 22	30	20	30	20	10
APX 80	60	40	50	30	20
APX 80	40	60	50	30	20
APX 82	100	70	90	70	45
APX 82	70	100	90	70	45
APX 84	130	80	110	90	60
APX 84	80	120	110	90	60
APX 86	160	100	150	130	85
APX 86	100	160	150	130	85



PATCH SIZE	L	W	L	W	C
APX 20	10	10	10	10	8
APX 22	60	15	15	15	10
APX 22	50	20	15	15	10
APX 40	80	10	40	25	15
APX 40	60	25	40	25	15
APX 24	60	1 Kabel			
APX 24	50	2 Kabel			

PATCH SIZE	L	W	L	W	C
APX 20	10	6	10	10	8
APX 40	80	10	40	20	15
APX 40	60	20	40	20	15
APX 42	110	10	50	30	20
APX 42	80	25	50	30	20
APX 44	130	20	70	40	25
APX 44	80	40	70	40	25
APX 25			25	15	
APX 35			35	25	
APX 45			60	40	
APX 24	80	1 Kabel			
APX 24	80	2 Kabel			
APX 26	120	1 Kabel			
APX 26	60	3			

PATCH SIZE	L	W	L	W	C
APX 20	6	6	8	8	6
APX 40	60	10	20	15	10
APX 40	35	15	20	15	10
APX 42	100	10	50	25	20
APX 42	80	25	50	25	20
APX 44	130	20	70	40	25
APX 44	80	40	70	40	25
APX 26			20	10	
APX 36			30	20	
APX 45			60	40	
APX 26	120	1 Kabel			
APX 26	60	3 Kabel			
APX 28	140	1 Kabel			
APX 28	80	2 Kabel			
APX 40	30	12	12	12	10
APX 42	100	10	30	20	20
APX 42	60	20	30	20	20
APX 44	130	20	50	30	25
APX 44	60	30	50	30	25
APX 46	100	40	70	40	30

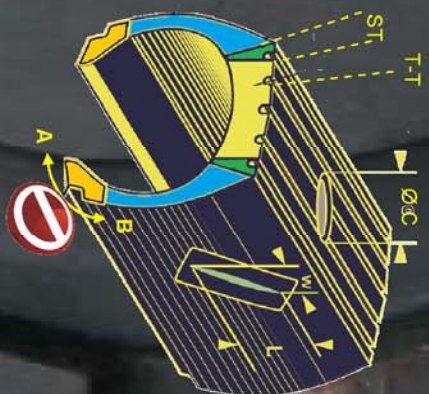

**AB** Non Repairable Area  
**C** Max Diameter of damaged Radial cable  
**W** Width of injury  
**L** Length of injury  
**S** Shoulder area  
**T** Crown area  
**A-B** Non Repairable Area  
**CARS** und **TRUCKS** 40mm  
**DETERMINING SIZE EXAMPLE**  
 6.50-7.00 (165-195) 65mm  
 7.50-16.00 (190-385) 75mm  
 17.5-23.5 (425-600) 90mm





**NEU !!**

**VERSACURE VON 20°C - 160°C**



BIAS PLY- TIRE PATCHES SERIES „A“.

A new developed patch, highly flexible, extremely resilient, with original factory double cushion.  
Cold vulcanisation with Maxibond cement, first coat on patch with Super Solution.

Hot vulcanisation with HL heating solution black.

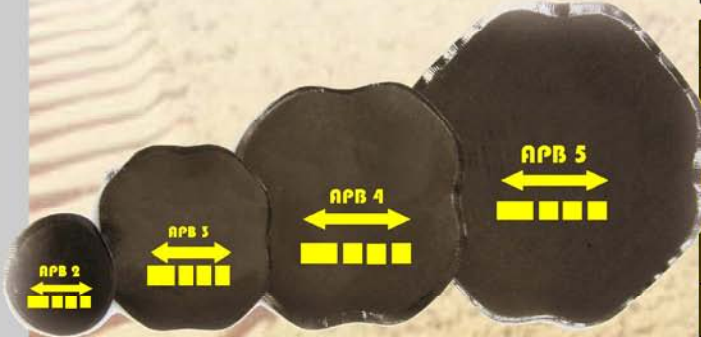

Cat.Nr.	Description	Comparison	Size /mm	Layers	Unit/box
067502	APB 2	PN02	83	2	20
067503	APB 3	PN03	100	2	10
067504	APB 4	PN04	140	4	10
067505	APB 5	PN05	165	4	10
067506	APB 6	PN06	235	6	5
067507	APB 7	PN07	300	6	5
067508	APB 8	PN08	343	6	5
067509	APB 9	PN09	394	8	3
067510	APB 10	PN10	450	8	3



Cat.Nr.	Description	Comparison	Size /mm	Layers	Unit/box
067127	COTR-0	--	180	4	10
067128	COTR-1	PN050	240	8	10
067129	COTR-2	PN052	280	8	5
067130	COTR-3	--	290	12	5
067131	COTR-3 1/2	--	355	12	5
067132	COTR-4	PN051+	405	12	3
067133	COTR-5	--	455	14	1
067134	COTR-6	--	490	16	1
067135	COTR-7	--	520	20	1
067136	COTR-8	--	570	20	1

**Für beste Ergebnisse**

Starting with patches size 7 we recommend to double with an adequate layer of bonding gum. Bonding gum for hot application you find on page 1/12. Solutions for vulcanization you can find on page 1/11





PLIES									
DAMAGE	4	6 to 8	10 to 12	14 to 16	18 to 20	22 to 24	8 to 12	14 to 18	20 to 24
10mm	APB 2	APB 3	APB 3	APB 4	APB 5	APB 6	APB 2	APB 3	APB 4
15mm	APB 3	APB 3	APB 4	APB 4	APB 5	APB 6	APB 2	APB 3	APB 4
25mm	APB 3	APB 4	APB 4	APB 6	APB 6	APB 7	APB 3	APB 4	APB 5
35mm	APB 4	APB 4	APB 5	APB 6	APB 7	APB 8	APB 3	APB 4	APB 5
50mm	APB 5	APB 5	APB 6	APB 6	APB 8	APB 9	APB 5	APB 5	APB 6
75mm	⊘	⊘	APB 7	APB 7	APB 9	APB 9	APB 6	APB 6	APB 7
100mm	⊘	⊘	APB 8	APB 8	APB 9	APB 10	APB 7	APB 7	APB 8
125mm	⊘	⊘	⊘	APB 10	APB 10	⊘	⊘	APB 8	APB 8

PLIES								
DAMAGE	6 to 8	10 to 12	14 to 16	18 to 20	22 to 24	26 to 28	30 to 36	38 to...
13	COTR 0	COTR 0	COTR 0	COTR 1	COTR 1	COTR 1	COTR 1	COTR 1
25	COTR 1	COTR 1	COTR 1	COTR 1	COTR 1	COTR 1	COTR 1	COTR 1
40	COTR 1	COTR 1	COTR 1	COTR 1	COTR 1	COTR 2	COTR 2	COTR 2
50	COTR 1	COTR 1	COTR 2	COTR 2	COTR 2	COTR 2	COTR 2	COTR 2
65	COTR 1	COTR 1	COTR 2	COTR 2	COTR 2	COTR 3	COTR 3	COTR 3
75	COTR 1	COTR 2	COTR 3	COTR 3	COTR 3	COTR 3 1/2	COTR 3 1/2	COTR 4
100	⊘	COTR 2	COTR 3	COTR 3	COTR 3 1/2	COTR 3 1/2	COTR 4	COTR 4
125	⊘	⊘	COTR 3	COTR 3 1/2	COTR 3 1/2	COTR 4	COTR 4	COTR 5
150	⊘	⊘	COTR 3 1/2	COTR 3 1/2	COTR 4	COTR 5	COTR 5	COTR 6
175	⊘	⊘	⊘	COTR 4	COTR 5	COTR 5	COTR 6	COTR 6
200	⊘	⊘	⊘	⊘	COTR 5	COTR 6	COTR 7	COTR 7
225	⊘	⊘	⊘	⊘	COTR 6	COTR 6	COTR 7	COTR 7
250	⊘	⊘	⊘	⊘	⊘	COTR 7	COTR 7	COTR 8
275	⊘	⊘	⊘	⊘	⊘	COTR 7	COTR 8	COTR 8
300	⊘	⊘	⊘	⊘	⊘	COTR 8	COTR 8	COTR 8

TIRE REPAIR CHART



**For best results**

**BUFFING TOOLS PAGE 2 / 01**

PLIES		
DAMAGE	4	6 to 10
3mm	⊘	⊘
6mm	⊘	⊘
13mm	⊘	⊘
25mm	APB 3	APB 4
40mm	APB 5	APB 6
50mm	APB 5	APB 6
65mm	APB 6	APB 7
75mm	APB 6	APB 7
90mm	APB 8	APB 7
100mm	APB 8	APB 8
125mm	APB 8	APB 9
150mm	APB 9	APB 9
175mm	APB 9	APB 9
200mm	⊘	APB 10
235mm	⊘	APB 10

This is an internationally valid repair chart. The figures referring to the extent of damage have been arrived on the basis of practical experience, bench checks and tests. Always make a general check to ensure that the tyre can be repaired. Examine the complete tyre for further hidden damages. The maximum limits for the repairable injuries indicated must not be exceeded. Repair limits that exist in individual countries have not been taken into consideration in this chart. When referring to this repair chart, the user is obliged to assess whether the indicated safety limits should be increased, by taking into account these regulations and local road, load and operating conditions. Follow the corresponding fitting and processing instructions when carrying out repairs.





Vehicle	Damage Ø			
	3 mm	RMT 0	RMT 0	RMT 0
	4,5 mm	VSMT 1	VSMT 1	VSMT 1
	6 mm	-	VSMT 1	VSMT 1
H - V	3 mm	RMT 0	RMT 0	-
	4,5 mm	VSMT 1	VSMT 1	-
	6 mm	-	VSMT 1	-
W - ZR	3 mm	-	RMT 0	-
	3 mm	-	RMT 0	RMT 0
	4,5 mm	-	VSMT 1	VSMT 1
	6 mm	-	VSMT 1	VSMT 1
	8 mm	-	VSMT 2	-



Cat No	Discription	Compare	Size mm	Unit/box
067231	<b>1</b> TR 218a V7/FER	5010277	80	10

Cat No	Discription	Compare	Size mm	Unit/box
067222	<b>3</b> TR13/15	5010136	60	10
067220	<b>4</b> TR15	5010150	60	10

PP TUBE PATCHES

Self vulcanizing Chemical cure patches for tubes.  
Use with **SUPER-SOLUTION !!**

Cat No	Form	Discription	Compare	Size mm	Unit/box
067001		PP-0	No.0	30	150
067002		PP 1	No.1	38	100
067003		PP-2	No.2	48	60
067019	Repairset Bike T006				

Cat No	Form	Discription	Compare	Size mm	Unit/box
067004		PP-3	No.3	56	44
067005		PP-4	No.4	75	32
067006		PP-5	No.5	95	10
067007		PP-6	No.6	116	10
067008		PP-7	No.7	76*37	45
067009		PP-8	No.7a	102*44	35
067010		PP-9	No.7b	160*76	10
067011		PP-10	No.7c	190*95	10
067012		PP-11	--	255*54	10

CHEMICAL MULTI REPAIR PATCH for bias & radial

Chemical cure heavy duty, all ruber, non rainforced, nailhole patch for injuries up to 8mm. Puncture must be filled with plug filing material. Foil backed. **Use with MAXI-BOND!!**

Cat No	Form	Discription	Compare	Size mm	Unit/box
066998		SMT 0	UP-3	32	50
067000		SMT 1	UP-6	57*57	50
066999		SMT 2	UP-8	65*65	40

TUBE REPAIR VALVES

Chemical cure units allow pernanet replacement of valves  
Bevor repair always manuell buffing the tube !

Cat No	Discription	Compare	Size mm	Unit/box
067237	<b>2</b> VG8/80 BVU	5010507	80	10

Cat No	Discription	Compare	Size mm	Unit/box
067215	<b>5</b> gerade	5010040	45	10
067216	<b>6</b> 70° gebogen	5010071	45	10
067217	<b>7</b> 90° gebogen	5010088	45	10



### MAXI SEAL PLUG PATCHES WITH METALL WIRE

Die kombinierte Innen-/Außenreparatur von Laufflächen für Radial- und Diagonal-Reifen **Verarbeitung mit SUPER-SOLUTION !!**



Cat No	Discription	Compare	Size mm	Unit/box
061045	M3	5111963	3	60
061145	Werkstattsortiment M3	5111956	3	20
061044	M4,5	5113215	4,5	24
061144	Werkstattsortiment M4,5	5113208	4,5	24
061046	M6	5113057	6	24
061146	Werkstattsortiment M6	5113040	6	24
061043	M9	5113105	8	24
061143	Werkstattsortiment M9	5113095	8	24

Jedes Werkstattsortiment wird inkl. 1 Raufräser und 60gr Vulkanisationslösung geliefert



### MAXI-SEAL XP MIT EINVULKANISIERTEM FÜHRUNGSDRAHT

Die kombinierte Innen-/Außenreparatur von Laufflächen für Radial- und Diagonal-Reifen.

- Gummikörper mit Lagenverstärkung bis zu einem LI von 220
- Das Durchziehen in den Stichkanal wird durch den einvulkanisierten Führungsdraht wesentlich erleichtert !

Verarbeitung mit **MAXI BOND CEMENT !!**



Art.Nr.	Bezeichnung	Vergleich	Maße / mm	Stk/VPE
061060	10 XP	--	10	10
061061	13 XP	--	13	10

### QUILLSEAL

Die kombinierte Innen-/Außenreparatur von Laufflächen für Radial- und Diagonal-Reifen. **Mit Metallschutzhülse zum Einführen in den Stichkanal.** Diese komfortable Variante der Nagellochreparatur vereint viele Vorteile in sich und wird von immer mehr Anwendern bevorzugt.

- Der Reparaturkörper wird durch die Hülse geschützt u. kann beim Einziehen durch hervorstehendes Stahlcordgewebe nicht verletzt werden !
- Das Einschieben in den Stichkanal wird durch die Hülse wesentlich erleichtert !
- Abreißen des Reparaturkörpers ist nahezu unmöglich, daher keine Materialverluste bei der Anwendung !

Verarbeitung mit **SUPER-SOLUTION !!**



Art.Nr.	Bezeichnung	Vergleich	Maße / mm	Stk/VPE
061049	QS50R	--	3	48
061047	QSR2	--	6	48

### MINISEAL MIT EXTRA DRAHTSONDE

Die kombinierte Innen-/Außenreparatur von Laufflächen für Radial- und Diagonal-Reifen. **Die Reparaturkörper werden per Drahtsonde eingezogen!** Verarbeitung mit **SUPER-SOLUTION !!**



Art.Nr	Bezeichnung	Vergleich	Maße /mm	Stk/VPE
061048	MSR2	5113071	6	48
061125	TSR1	5113129	8	24







**061142 RUN-FLAT**

With the Run Flat Tyre Performance Kit it is possible to repair easy and fast crown damages successfully. For an successfully repair we have combined high quality tools and special instructions to ensure your success with this tire repair.

**RUN-FLAT PERFORMANCE KIT:**

- |                                       |                            |
|---------------------------------------|----------------------------|
| 061045/ M3 20 pcs.                    | 016004/ Stitcher           |
| 061044/ M4,5 12 pcs.                  | 018119/ Knife              |
| 061046/ M6 12 pcs.                    | 067330/ Spiral Cement tool |
| 060099/ Box                           | 067073/Rubbertex 600ml     |
| 019320/ Selection Tool                | 067063/SS-Lösung-235ml     |
| 017004/Rubber Scraper                 | 011883/Cutter-3 mm         |
| 067261/BLRSF/0,4L                     | 011882/Cutter-4,5 mm       |
| 011884/Cutter-5,8 mm                  |                            |
| Repair template / Using Instruktionen |                            |



**061141 TRUCK REPAIR KIT**

With the TRUCK TYRE Tyre Performance Kit it is possible to repair easy and fast crown damages successfully. For an successfully repair we have combined high quality tools and special instructions to ensure your success with this tire repair.

**TRUCK SORTIMENT PERFORMANCE KIT:**

- |                                     |                         |
|-------------------------------------|-------------------------|
| 061061 / XT 13mm 3 pcs.             | 067073/ Rubbertex 600ml |
| 061060 / XT 10mm 5 pcs.             | 016003 / Stitcher       |
| 067330 / Spiralhandstichling 1 pcs. | 014345 / Buffing Ball   |
| 067261/ Innerliner Sealer 390ml     | 018119/ Knife           |
| 014947 / Cutter 13mm 1 pcs.         | 017040 / Rubber Scraper |
| 011619 / Cutter10mm 1 pcs.          |                         |
| 067068 / Maxi Bond Cement 500ml     |                         |

Repair template / Using Instruktionen



**061140 AGRAR REPAIR KIT**

With the AGRAR Tyre Performance Kit it is possible to repair easy and fast crown, sidewall and shoulder damages successfully. For an successfully repair we have combined high quality tools and special using instructions to ensure your success with this tire repair.

**AGRAR PERFORMANCE KIT:**



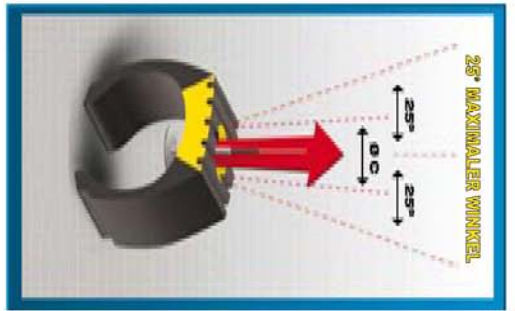

- |                                       |                               |
|---------------------------------------|-------------------------------|
| 060009 Agrar-Comp.FR909N60            | 067507 Diagonalpflaster APB 7 |
| 067508 Biasplay Patch APB 8           | 067068 MBC-658F/500ml         |
| 067180 Radialpatch APX 80             | 067261 Repair Sealer 390ml    |
| 067286 Radialpatch APX 86             | 067073 Rubbertex 600ml        |
| 018841 Round Rasps 102*19             | 018119 Knife                  |
| 010889 Oxid Stone 6*105 K36           | 015896 Pencil Rasps8*170 K18  |
| 015060 RS-6-Adapter M12               | 010072 Drahtbürste 55*8 zyl.  |
| 010620 Schleifstift 6*6-weiß/I        | 019320 Selection Tool TRT105  |
| 015051 RS-8-Adapter M14/L20           | 017110 Knife1527              |
| 010888 Pencil Rasps 25*102-3/8-K16    |                               |
| 10420 Contour Wheels 75*38-K36        |                               |
| Repair template / Using Instruktionen |                               |





Dies ist eine international gültige Reparaturtabelle. Die angegebenen Schadensgrößen werden basierend auf Erkenntnissen der Praxis, Prüfstandskontrollen und Tests und Erfahrungen festgelegt. Generelle Instandsetzungsmöglichkeit des Reifens ist zu Prüfen! Gesamten Reifen auf weitere Schäden untersuchen. Die angegebenen maximalen Schadensabmessungen dürfen nicht überschritten werden. Eventuelle länderspezifische Reifenreparaturgesetze sind in dieser Tabelle nicht berücksichtigt. Die Schadenstabelle entbindet den Anwender nicht, sowohl unter Beachtung dieser Vorschriften als auch abgestimmt auf örtliche Straßen-, Belastungs- und Einsatzbedingungen von der Beurteilung, ob die angegebenen Sicherheitswerte zu erhöhen sind. Für den Reparaturablauf entsprechende Einbau- und Verarbeitungsanleitung beachten.

This is an internationally valid repair chart. The figures refer to the extent of damage have been arrived on the basis of practical experience, bench checks and tests. Always make a general check to ensure that the tyre can be repaired. Examine the complete tyre for further hidden damages. The maximum limits for the repairable injuries indicated must not be exceeded. Repair limits that exist in individual countries have not been taken into consideration in this chart. When referring to this repair chart, the user is obliged to assess whether the indicated safety limits should be increased, by taking into account these regulations and local road, load and operating conditions. Follow the corresponding fitting and processing instructions when carrying out repairs. [www.rei-pa.com](http://www.rei-pa.com)

 T-T Zone gemessen 70 % der Lauffläche T-T Zone gemessen 70 % der Lauffläche T-T Zone gemessen 70 % der Lauffläche	 T-T Zone gemessen 80 % der Lauffläche T-T Zone gemessen 80 % der Lauffläche T-T Zone gemessen 80 % der Lauffläche	 T-T Zone gemessen 80 % der Lauffläche T-T Zone gemessen 80 % der Lauffläche T-T Zone gemessen 70 % der Lauffläche	 T-T Zone gemessen 75 % der Lauffläche	MAX REPARATUR je REIFEN						NICHT REPARIERBAR GLEICHE EBENE 
				Speedindex	Load Index	Ø 3mm	Ø 4,5mm	Ø 6mm	Ø 8mm	
>J	M3	✓	✓	✓	✓	✓	✓	✓	2	
K-T	M4,5	✓	✗	✗	✗	✗	✗	✗	1	
H-ZR	M6	✓	✗	✗	✗	✗	✗	✗	1	
S-U	M8	✓	✗	✗	✗	✗	✗	✗	3	
H-V	M10XT	✓	✗	✗	✗	✗	✗	✗	2	
ZR-W	M13 XPT	✓	✗	✗	✗	✗	✗	✗	1	
-L 220		✓	✓	✓	✓	✗	✗	✗	3	
-L 189		✓	✓	✓	✓	✓	✗	✗	3	
-L 189		✓	✓	✓	✓	✓	✓	✓	2	
--		✓	✓	✓	✓	✓	✓	✓	4	





**CARBICE CUTTER**

For professional processing of spot channels. These tools are made of an extremely hard material and cut the damaged stahlcord from tyres . The tools have a very long life when properly use. **Speed max. 800**



CAT No	Discription	Compare	Size / mm	Unit / box
011883	Carbite Cutter	5954917	3	1 Stück
011882	Carbite Cutter	5955019	4,5	1 Stück
011884	Carbite Cutter	5954924	5,8	1 Stück



CAT No	Discription	Compare	Size / mm	Unit / box
011891	Carbite Cutter	5954948	7,8	1 Stück
011619	Carbite Cutter	5111619	10	1 Stück
014947	Carbite Cutter	--	14	1 Stück

**TAPERED DRILL BITS**

For easy editing of spot channels, for roughening and cleaning, as well to prepare the branch ducts before installation of repair bodies. For removal of injuries and fraying at steelcord not recommend these tools. **The lowest possible speed for these tools!**



CAT No	Discription	Compare	Size / mm	Unit / box
019401	Drill Bit	—	3	1 Stück
019403	Drill Bit	—	4,5	1 Stück
019402	Drill Bit	—	5,8	1 Stück
019404	Drill Bit	—	7,8	1 Stück

**SPIRAL AWL**

Transferable for the introduction of vulcanizing cement in random channels. The use of this awl makes a perfect wetting of solution channel and garanteed a perfect vulcanisation.

CAT No	Discription	Unit / box
067330	Spiralahle	1 Stück

**AWL**

Special awls for easy introduction of tire repair products like Seal It



CAT No	Discription	Range	For Product	Unit / box
067331	Pistol grip awl		SEAL IT PKW	1 Stück
067324	Pistol grip awl		SEAL IT LKW	1 Stück
067327	Sidways open awl		KWIK INSERT	1 Stück





### KWIK-INSERTS

Cured natural rubber wrapped in Versacure gum to seal the injury. Available in 2 sizes for truck, tractor and OTR tires. Use with an open-eye inserting tool 067327 and with Supersolution - Fast Dry cement.



Cat No.	Description	Injury	Compare	Unit / box	Awl
060057	V 502 LKW	6-10 mm	5102147	20	067327



Cat No.	Description	Injury	Compare	Unit / box	Awl
060058	V 503 EM	bis 20 mm	5102161	20	067327

### POF - PANGOFIL

Nylon filament and cured rubber, wrapped in Versacure gum to seal and vulcanize to the air. Available in two sizes. Use with a split-eye insert tool and Supersolution - Fast Dry cement



Cat No.	Description	Injury	Length	Unit / box	Awl
060050	POF-5	bis 6mm	100mm	50	067331



Cat No.	Description	Injury	Length	Unit / box	Awl
060053	POF-8	6-10mm	200mm	25	067324

### SEAL-IT

High strength twisted cord resists breaking. Dipped in soft tacky buty rubber to seal the injury. Quick and easy to install. One of the most popular types of nailhole repair



Cat No.	Description	Injury	Length	Unit / box	Awl
060100	SEALT IT SET	bis 6mm	--	1	--
060052	SEAL IT SS	bis 6mm	100mm	50	067331



Cat No.	Description	Injury	Length	Unit / box	Awl
060105	SEALT IT SET	6-10mm	--	1	--
060051	SEAL IT SSL	6-10mm	200mm	25	067324



\* / \*\* When using the product in the Federal Republic of Germany please Directive for the repair of tires VkB1.2001, refer to page 91:

3 General Requirements (excerpt): 3.1. Basically, each tire before repairing to the analysis of the damage ... to dismantle the rim ... / .... 3.3 are exclusively suitable for this repair agent to use to the manufacturer's instructions ..., it is ... on the compatibility the materials used to make each other. 3.5. Damage to tires, which were treated by puncture tool can not be repaired. 3.6. The insertion of a tube without the correct tire damage is not permitted.





**BUFSOL / RUBBERTEX**

To clean rubber surfaces prior to mechanical buffing. Prevents poor adhesion by dissolving mold release lubricant and other contaminants on the surfaces.



Cat.No.	Description	Compare	Centents	Mastercarton
067071	Bufsol	LB 5059702	1000 ml	12 Dosen
067072	Bufsol	LB 5059719	5000 ml	1 Kanne
067073	Rubbertex-Spray	LB 5059692	600 ml	24 Dosen
065902	Pango-Clean	5959125	1000 ml	12 Dosen



**USAGE TIP !! USE RUBBER CLEANER BEFORE MANUAL BUFFING**



**SUPER SOLUTION**

Fast drying, non-flammable vulcanizing fluid, for tube and tire repairs. Use with Chemical and Versacure repairs, hot or cold cure



Cat.No.	Description	Compare	Centents	Mastercarton
067063	Super-Solution 608	Vulk-Flüssigkeit	235ml	24 Dosen
067065	Super-Solution 609	Vulk-Flüssigkeit	500ml	12 Dosen
067064	Super-Solution 610	Vulk-Flüssigkeit	950ml	12 Dosen
067059	Super-Solution Tube	Vulk-Flüssigkeit	20ml	20 Tuben



**MAXI BOND CEMENT**

Is a premium non-flammable heavy duty blue cement that meets requirements for high tack and superior adhesion of repair units. Maxiband dreis faster than similar competitive cements. High recommended for chemical repair units used in thire repair hot or cold. 18°C– 150°C



Cat.No.	Description	Compare	Centents	Mastercarton
067066	Maxicement 658	Cement-BL	235 ml	24 Dosen
067068	Maxicement 657P	Cement-BL	500 ml	12 Dosen
066590	Maxicement 661	Cement-BL	950 ml	12 Dosen



**INNERLINER SEALER**

Restores the air retention of butyl inner liner with a non-flammable butyl rubber compound. Recommended for repairs of blister in tubless inner liners.



Cat.No.	Description	Compare	Centents	Mastercarton
067061	Innerliner-Sealer	5159004	950 ml	12 Dosen
067261	Innerliner-Sealer	5159004	500 ml	12 Dosen



### BEAD SEALER

Spreadable sealant for sealing leaks caused by aging on the beads. BEAD SEALER is applied to bead and bead seat before starting to pump the tire. The solids contained in the solution in the subsequent inflation of the unevennesses pressed, whereby they are locked.



Cat.No.	Description	Compare	Centents	Mastercarton
067461	Bead-Sealer	5159004	950 ml	12 tin



### FLUID PATCH

To seal the repair of SEAL IT and POF. Serves as pavement replacement

Cat.No.	Description	Compare	Centents	Mastercarton
067262	Fluid Patch	—	250ml	24 tin



### HL-HEATING SOLUTION

High tack black vulcanizing cement used when a repair is cured with heat. Use to apply uncured patches and cushion gum in tire repairing. This cement is the only one needed for Vercacure repairs in most retreading curing systems. HL-SOLUTION is matched in acceleration and prison system, on PR-GUM, and can therefore be used above 100 ° C curing temperature.



Cat.No.	Description	Compare	Centents	Mastercarton
067074	HL-Heizlösung	516 9207	500ml	12 tins
067069	HL-Heizlösung	516 9214	1000ml	12 tins
067070	HL-Heizlösung	516 9240	5000ml	1 can



### RAPID SOLUTION

HL-HOT-CEMENT, for temperature starting at 95°C. For patches Series "S" without pretreatment. Cement contains trichloroethylene. A fast drying penetrating, heat curing cement. Use with repairs which are vulcanized with heat and pressure.



Art.Nr.	Bezeichnung	Vergleich	Inhalt	Masterkarton
067058	Rapid-Solution	5161061	4000 ml	1 KANNE



### For best results !



Original Products from REINHEIMER !





062002



064004



062024



062025

**INDUSTRIAL GLUE RP 4004 / RP3003**

Environmentally friendly two part all-purpose chloroprene liquid cement that provides high initial tack and excellent adhesion characteristics. Oil and chemical resistant, it is excellent for splicing belts, bonding belt repair strips and patches, and bonding rubber to rubber, whether natural rubber, SBR, Neoprene, etc. Provides excellent adhesion for cleat fabrication and in rubber to metal applications.

High dynamic load capacities characterize the bonded joint. We recommend to achieve the best results using appropriate primers and cleaners from our range.

RP Glue Series is mixed with Activator at a ratio of 1:5. Environmentally friendly RP Glue is a flammable mixture. The working temperature range of the product is -23° to 85°C. Cures to a usable bond in 4-6 hours. Full cure in 24 hours (21°C).

Cat.No.	Description	Contents	Mastercarton
062002	Glue 3003-sw	1-Kg	10 Dosen
062005	Glue 3003-sw	5-kg	4 Kannen
064004	Glue 4004-sw	1-Kg	10 Dosen
064005	Glue 4004-sw	5-kg	4 Kannen

**INDUSTRIAL GLUE PLASTOFIX**

Two part PVC liquid cement. PLASTOFIX is a flammable bonding cement for PVC and Polyurethane. It is excellent for splicing polyurethane belts, splicing PVC belts, and bonding PVC cleats, V guides and edge walls. PLASTOFIX can be mixed with activator at a ratio of 1:5.

The working temperature range of the product once cured is -23°C to 70°C. Plastofix cures to a usable from 4-6 hours Full cure in 24 hours 21°C

Cat.No.	Description	Contents	Mastercarton
062024	Plastofix	750gr	10 tin
062025	Plastofix	25 Liter	1 can



QR Code for using instruction



### METAL-PRIMER

Bonding agent for rubber-metal bonding with high demands on static and dynamic strength. This one-component products with short drying time are suitable for the preparation of a variety of metal surfaces and ensure high initial strength of rubber-metal bonding. Used to prime all metal or concrete substrates before applying adhesives. **Shake well before each using.**

Cat.No.	Description	Centents	Mastercarton
062001	Metallprimer	700ml	10 Dosen



062001

### CLEANER FOR PVC CONNECTION / PLASTOFIX

Cleaning solvent for removing grease, oil and other contaminants from PVC products. The result is a perfectly clean bonding surface, the optimal conditions for a high-strength adhesive.

Cat.No.	Description	Centents	Mastercarton
062026	MEK-REINIGER	1000ml	10 Dosen



062026

### CLEANER FOR RP 3003 / RP 4004

Cleaning agent for removing grease, oil and other contaminants from rubber and metal. The result is a perfectly clean bonding surface, the optimal conditions for a high-strength adhesive.

Cat.No.	Description	Centents	Mastercarton
067076	MEK-REINIGER	1000ml	10 Dosen



067076

### ACTIVATOR

Chemical activator designed for two part cold bonding cements such as RP3003 / RP 4000 and PALSTOFIX. Increases the connection between the products to be processed, and allows a faster drying between the product.

Cat.No.	Description	Centents	Mastercarton
062003	ACTIVATOR 1000M	40 ml	10 Flaschen
062004	ACTIVATOR 1000M	200 ml	10 Flaschen
062009	ACTIVATOR 1000E	30 ml	10 Flaschen
062006	ACTIVATOR 1000E	200 ml	10 Flaschen



### ELIFLEX REPAIR GROUND

Eli-Flex can be used on all types of rubber and PVC belts. This includes fabric carcass, steel cable and steel cored belts. Eli-Flex is suitable for repairing holes, tears, splits, rips, gouges, missing filler strips, worn patches, clip joint / fastener sealing, edge repairs, re-building cleats, chevrons and sidewalls, worn drum lagging, roller coatings and friction linings

Cat.No.	Description	Centents	Mastercarton
060007	ELIFLEX	100 gr	10 Bags







066080  
066081  
066082



067197



067307



**GHC GUM COLD CURE**



Uncured natural rubber cushion gum with special properties that allow the gum to vulcanize at room temperature. Use with Super Solution - Fast Dry cement for selfvulcanisation.  
Waiting time before start least 48 hours at 18 ° C.



Cat. No	Description	Compare	Thickness	Weight / roll	USE
067081	GHC Bindegummi	5153509	0,8mm	3,9kg	Cushing Gum

**A+B COMPOUND / AGRARCOMPOUND**



Two part self vulcanizing putty. When the two parts are mixed together they will vulcanize at room temperature. Ideal for tires and all types of rubber. Especially for working, construction machinery and agriculture. Vulcanizing 70h at 20 ° C.



Cat. No	Description	Compare	Weight / roll	USE
067075	Pangit A+B	5169025	1-Kg	
060009	Agrarcompound	--	150gr	
067085	Pangit-Mischer	--	--	--

**UNIVERSAL PNP NAILHOLE PATCHES**



With nylon fabric reinforcement for radial and bias tires, working with HL-heating solution, heating temperature from 100 ° C. Coated on both sides with foil, yellow side after removing the foil for the rough location, top film before heating remove unbedingt. Use heating foil 067197



Cat. No	Description	Compare	Size	Qty / Box
066080	PNP-1	5171006	30mm	50 pieces
066081	PNP-2	5171020	50mm	50 pieces
066082	PNP-3	5171037	47mm	50 pieces
067197	Heating Foil	5171972	160*75mm	500 pieces

**RADIAL NAILHOLE PATCHES**



With nylon insert. The patch with the type designation PN81-1 is characterized by a very strong fabric and is mandatory for use in retreading area partly to achieve the standard requirements. Use with HL-Solution and heating foil 067197



Cat. No	Description	Compare	Size	Qty / Box
067307	PN81-1	5171817	65*55 mm	20 Stück

**REPAIR GUM / CUSHING GUM / CURE RUBBER**



All purpose natural rubber cushion gum. RMA Cure Class 95°C cures twice as fast as standard cure gums allowing a reduction in curing time for increased productivity. Use with HL-Solution



Cat. No	Description	Compare	Thickness	Weight / roll	USE
067080	PR-32	--	0,8 mm	5kg/460mm	Cushing Gum
067083	PR-32/3	5161243	0,8 mm	1,7kg/150mm	Shore 45
067084	LA-15	--	1,6 mm	0,9Kg 25mm	Shore 55
067082	PR-18	5161274	3,9 mm	5,0kg/460mm	Shore 55

**LOW TEMPERATURE ROPE RUBBER**

066090	LRR-LTC	5161023	0,8mm	14 kg	Shore 45
065835	TRR-REG	5161023	0,8mm	14 kg	Shore 55



### RILLFIT STATION



Tyre holder for easy and effortless regrooving of Truck tires (17.5"-24.5")  
The tires can be cut with or without rim. Very easy is the automatic drive. It is operated via a foot pedal.

Dimensions (L \* W \* H) 1100 \* 1100 \* 1150)



Cat No	Description	Compare		Qty
061701	RF Station	5183719	--	1 piece

### RILLFIT GERÄT



Designed for heavy-duty use, RILLFIT VI allows quick and precise regrooving of the tire tread. Through the separate handle vom Trafo absolute freedom of movement and ease of management is achieved. The ergonomic design of the handle allows an ermüdungsfreies work. The High-Tech transformer with thermal protection allows a non-stop cutting according to DIN 30600 and has a very long life. RILLCUT also compatible with all cutting blades having a width of 3-28mm.



Cat No	Description	Form	Compare	Deep	Width	Qty.
061702	Rillfit 6		5641017	--	--	1 St.
061711	W1		5642858	7	3-4	20 St.
061712	W2		5642865	8	5-6	20 St.
061713	W3		5642872	10	6-8	20 St.
061714	W4		5642889	14	9-10	20 St.
061715	W5		5642896	16	10-14	20 St.
061716	W6		5642906	16	17-20	10 St.
061721	R1		5642803	7	3-4	20 St.
061722	R2		5642810	8	5-6	20 St.
061723	R3		5642827	10	6-8	20 St.
061724	R4		5642834	14	9-10	20 St.
061725	R5		5642841	16	10-14	20 St.



**SPARE PARTS FOR ALL RILLFIT EQUIPMENT AVAILABLE!**

### HEATING STEMP



For thermal labeling of tires. Special characters such as &,% , etc. available on request. If required, other character heights of 5-50mm can be supplied. Well plates in complete combustion own brand can be offered.

Cat No	Description	Power	Compare	Size	Width	Height	Milling
061708	Typ3	300	5190977	70*35	7 mm	--	15 mm
061707	Typ4	400		90*40	9 mm		15 mm
061718	Typen A-Z	--	--	--		12 mm	15 mm
061719	Ziffern 0-9	--	--	--		12 mm	15 mm



### TREAD DEPTH GAUGE / DIGITAL PRESSURE CONTROLLER



This tester belongs in every vehicle - it allows for both quick test of tire pressure and measuring the tread depth.  
As an alternative to this device we still perform a depth gauge brass with protective bag

Cat No	Description	Size	Pressure	Compare
011221	Tread Depth	0mm-30mm	--	5191653
011223	Digitale Lehre	0mm-15,8mm	0-10bar	5191828







**SPOTTERS**

For years REINHEIMER Thermopress hot tyre repair systems are an integral part for the tyre repair program. With these devices, most defects of the tread, sidewall and shoulder, and also cosmetic repairs can be performed. The sturdy construction ensures a long service life. Operating temperature 145 ° C!



Cat No	Description	Power	Supply	Operation
061670	VP4	2* 600 Watt	220V / 50 Hz	Druck pneumatisch geregelt



Cat No	Description	Power	Supply	Operation
061662	VP5	2* 600 Watt	220V / 50 Hz	Druck mechanisch geregelt

**EQUIPMENT FOR SPOTTERS**

Cat No	Description	Application	Compare	Dimension
061015	Base Stand	M40 und P50	--	--
067385	Pressure Pad		5173853	110*110
061767	Pressure Pad		5172438	180*130
061768	Pressure Pad		5171989	210*150
061764	Pressure Pad		5171965	260*100
061664	Hotplate-Faip PV	M40/P50 oben	--	600-Watt
061665	Hotplate-Faip PA	M40/P50 unten	--	600-Watt
061439	Replacement thermostat	Lamco und TT	5171439	max. 155°C
092056	Timer Lamco	M40/P50	ohne Bild	--
061763	Hotplate TT	nur TT	5173578	300-Watt
061765	Plating Nr.3		5173231	--
061770	Plating Truck		5173224	--

**HEATING MOULD LATEX 16**

For all radial and bias tires, with major damage to the tread and sidewall. These devices were designed based on the known and proven Heizmulden. Through the use of electronic and pneumatic Steuerungselementenist been able to make these devices inexpensive and efficient.

- simultaneous heating of the inner-u. Outside
- Different shape of the tire shoulders changeable!
- Outdoor and indoor temperature controlled separately via electr.
- Thermostats, digital display!
- Heating time is automatically controlled and displayed digitally!
- mechanical form of outside pressure on pneumatic air cushion inside.
- Analog display, adjustable!
- Automatic clock control for the uniform structure

**TYRE SIZES**  
 L-LKW: 6-00-16 to 8-25-15. Traktor 6-00-16 to 11-00-16. 9-24 to 650/70-32.  
 LKW: 7-00-20 to 18-22'5. EM: 13-00-24 to 23/5-25.



Cat No	Description	Applications Areas
068009	LATEX 16	

**HEATING MOULD 50**

**THE TOP MODEL UNDER THE EUROPEAN HEATING MOULD - LATEX 50 for EM and agricultural tires!**

The MOULD LATEX 50 works on the same principle as the smaller model already described, Latex 16, this model is to be used for very large tires.

**TYRE SIZES**  
 EM 17.5-25 to 45/65-45 AGRAR 1050/50-32



Cat No	Description	Applications Areas
068049	LATEX 50	



### CONTOUR CUPS HALF-ROUNDED

Recommended speed max. 4500 RPM. Premium quality products MADE IN EEC.



Ref. Nr.	010886	013828	013829	010420	010422	010423	010424
Grit	18	36	60/BC1	36	18	36	18
Measure mm D/H	50*25	50*25	65*14	76*32	76*32	102*38	102*38
Thread / Hole	3/8"	3/8"	10	14	14	14	14
Usage							

### ROUND FACED RASPS

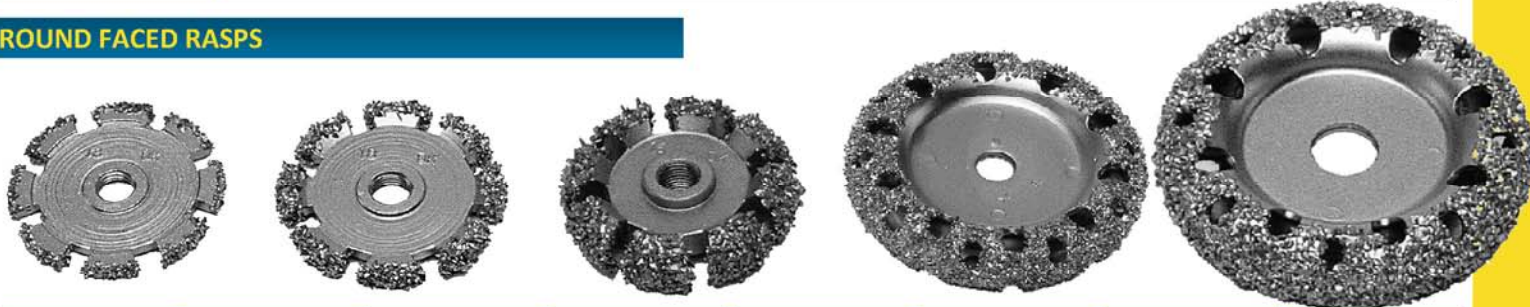

Ref. Nr.	013560	013570	013590	010885	010882	018834	018841
Grit	18	18	18	18	18	18	18
Measure mm D/B	50*3,5	50*5	50*7	50*10	50*19	76*19	102*19
Thread / Hole	3/8"	3/8"	3/8"	3/8"	3/8"	14	14
Usage							

### TAPERED CONE-/ PENCIL-/ BALL RASPS



Ref. Nr.	010889	010612	015896	015897	010887	010888	013920
Grit	fine	coarse	coarse	fine	18	18	18
Measure mm L/D	105*6	105*6	170*8	170*8	25*50*3/8	25*102*3/8	19*6mm
Usage							

### RUBBERHOG® BUFFING TOOLS

For fine treatment of rubber surfaces.

Ref. Nr.	010108	010152	010635
Grit	fine 36	—	feine
Measure	65mm	—	—
Description	Cup Rasp	Poly insert	Fine buff set
Sizes SEK	015063		
Sizes RUS	015371		

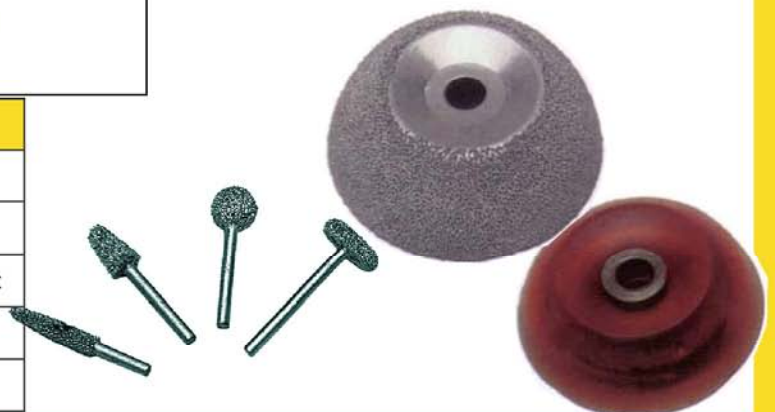





019667, sowie 8, 10, 11mm



015070+71

015367.68,40

015021

45mm

20mm



010665

015152

**QUICK CHANGE ADAPTORS HEX**

Ref. Nr.	Size in mm	Usage
010661	3/8*16mm	Buffing wheel/ rasp
015063	3/8*25mm thread lenght	Cup rasp
015062	M14	Cup rasp
010666	M14 /M16 Adapter	Wire brush w. PU-inset
019678	All tools with 3mm shaft	Steel cable burr
019667	All tools with 6mm shaft	Steel cable burr
016689	All tools with 8mm shaft	Steel cable burr
016593	All tools with 10mm shaft	Steel cable burr
016594	All tools with 11mm shaft	014949+4947
010665	NV11 R5/R6	Blade set R5/R6

**CHUCKS WITH ROUND SHANK FOR ALL BUFFING AIR TOOLS**

Ref. Nr.	Size in mm	Usage
015370	8mm*3/8	All buffing tools 3/8"
014216	6mm*3/8	Buffing wheel.BC1
015057	6mm*M10	All tools bore 10mm
015059	8mm*M10	All tools bore 10mm
015060	6mm*M12	All tools inside 12mm thread
015426	14mm	Disc bore 14mm
015152	8mm*12,7mm	For blades R5 u. R6

**COLLET CHUCK WITH MORSE CONE FOR MK1 BIAX-SHAFTS**

Ref. Nr.	Size in mm	Usage
015070	6mm	All tools with 6mm shank
015071	8mm	All tools with 8mm shank
015075	6mm	Replacement chuck jaws
015076	8mm	Replacement chuck jaws

**TOOL HOLDERS FOR MK1 FOR BIAX-SHAFTS**

Ref. Nr.	Size in mm	Usage
015367	3/8 MK1	Buffing Wheels
015368	3/8 MK1	Forchuck on shank
015040	M12 MK1ew.	Ball M12 inside thread
015021	M14 MK1 14mm	Chuck width 45 mm bore 14 mm
015150	12,7mm	For blade set R5 and R6

**BUFFING RASPS FOR PREPARATION OF CROWN**

Ref. Nr.	Type	Description
011791	R5	Blades 45mm/bore.12,7mm/ set 5-pieces
011792		Set distance plates for set blades - R5
011796	R6	Blades 75mm/bore.12,7mm/ set 6-pieces
011797		Set distance plates for set blades - R6

Chucks: Round shank 015152, for quick coupler 010665.  
 Morse cone for flexible shaft 015150  
 Check beforehand your requirements of distance plates when placing a order !!



### GRINDING WHEELS

For grinding and removal of damaged steel cord for radial tires.



Ref. Nr.	Sizes	Arbor	Texture	Usage	Qty
014181	100*15	16	fine		1
014190	80*10	16	fine		1
014191	80*8	16	fine		1
014200	71*8	16	fine		1

### GRINDING CONE WITH SHAFT 6mm

For grinding and removal of damaged steel cord for radial tires.



Ref. Nr.	Sizes	Shaft	Texture	Usage	Qty
014270	40*40	6 mm	soft -fine		5
014280	30*30	6 mm	soft -fine		5
014290	30*30	6 mm	soft -coarse		5
014300	30*30	6 mm	hard fine		5
014310	20*65	6 mm	soft fine		5

### CUTTER DISCS

For grinding and removal of damaged steel cord for radial tires.



Ref. Nr.	Sizes	Shaft	Texture	Usage	Qty
014360	55*10	6 mm	fine grey SI/CA		5
014370	25*10	6 mm	Soft -fine		5
014371	25*10	6 mm	hard -fine		5

### GRINDING PENCIL



Ref. Nr.	Sizes	Shaft	Texture	Usage	Qty
010621	6*6	6 mm	hard fine / red		5
010620	6*6	6 mm	soft/ white		5

### GRINDING BALL WITH SHAFT 6mm



Ref. Nr.	Sizes	Shaft	Texture	Usage	Qty
014340	20	6 mm	soft -white		2
014345	40	6 mm	shell -coarse		2
014350	25	6 mm	hard -fine-red		2

### GRINDING ROLLER WITH SHAFT 6mm

Ref. Nr.	Sizes	Shaft	Texture	Usage	Qty
014240	30*30	6 mm	hard -fine		2
014250	30*30	6 mm	Soft -coarse		2

### GRINDING BALL WITH ARBOR HOLE



Ref. Nr.	Sizes	Arbor	Texture	Usage	Qty
014170	60	12mm	coarse		1
014171	60	12mm	fine		1
014161	50	12mm	fine		1

### ROTARY GOUGE ROUND



Ref. Nr.	Sizes	Arbor	Texture	Usage	Qty
014100	90*30	16mm	soft-fine		1
014101	100*30	16mm	hard -coarse		1
014102	80*30	16mm	hard -coarse		1
014110	90*30	16mm	hard -coarse		1

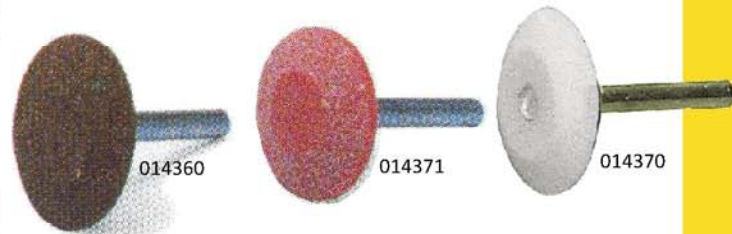





WOBBLE BRUSHES WITH SCHAFT 6mm			
Ref. Nr.	Diameter / mm	Width / mm	Grit
015450	60	20	120
015460	80	20	80
015470	80	20	120
015471	80	30	80

WIRE BRUSHES STAINLESS STEEL WITH SCHAFT 6mm			
Ref. Nr.	Diameter / mm	Width / mm	Wire
014690	30	12	0,2
014700	40	12	0,2
014710	40	16	0,2
014720	60	12	0,2
014730	60	18	0,2

BRASS WIRE BRUSH WITH SCHAFT 6mm			
Ref. Nr.	Diameter / mm	Width / mm	Wire
010072	55	8	0,2

WIRE BRUSH WITH PLASTIC ENCAPSULATED BRISTLES			
Ref. Nr.	Diameter / mm	Width / mm	Arbor
019545	45	7	Bore 3/8"
010416	76	7	Bore 14mm
010417	76	20	Bore 14mm

ROUND BRUSHES FOR BUFFING MACHINES ARBOR				
Ref. Nr.	Diameter / mm	Width / mm	Bore	Wire
014600	75	16	14mm	0,2
014620	100	20	14mm	0,3
014622	100	28	14mm	0,3
014654	160	60	76mm	0,27

STICKLEBACKS			
Ref. Nr.	Length mm	Ø mm	
019420	120	5	For cleaning and roughening holes.
019440	250	8	

WIRE BRUSHES			
Ref. Nr.	Rows	Material	Wire-Strength / Length
014849	2	Steel	0,2mm / 25mm
014850	4	Steel	0,2mm / 25mm
014860	5	Steel	0,2mm / 25mm
014880	4	Brass	0,2mm / 25mm

ROUGHENING SCRAPER		
Ref. Nr.	Description	
017004	Tire scraper	For good cleaning of damaged areas in conjunction with RUBBERTEX
014910	Roughening scraper	
014911	Replacement pad	

BRAKE CALIPER BRUSH	
Ref. Nr.	Description
011968	Brake caliper brush

PROBING TOOL		
Ref. Nr.	Description	
019300	Probing tool 3mm	019320 additionally owns colored marking rings for different hole diameters up to 10mm.
019310	Probing tool 6mm	
019320	Probing tool 10mm	



### GRINDING TOOL WITH ROUND SHANK 6mm



Grit 50 / Max RPM 2800 U/min / Wear safety goggles!!

Ref. Nr.	Description	Sizes	Verw.	Qty / Pcs
015408	Base body	46*30		1
015411	Grinding sleeve	46*30		10
015405	Base body	75*30		1
015407	Grinding sleeve	75*30		10

### BUFFING BRUSH



For subsequent brushing of rough scars/  
For better chemical reaction

Ref. Nr.	Description	Sizes	Verw.	Qty / Pcs
010540	WB 3F	76*6		3
010510	Adaptor H4			1



### SAFETY/ PROTECTION GOGGLES

Ref. Nr.	Description	Info	Verw.	Qty / Pcs
012006	Safety glasses	ADJUSTABLE		1
012056	Replacement glasses			1
016101	Protection goggles	OVERGOOGLES		1



### HEARING/BREATHING PROTECTION

Ref. Nr.	Description	Info	Verw.	Qty / Pcs
012030	Capsular ear protection			1
014150	Fine dust mask			10



### BEAD TAPE MEASURE

For the measurement of bead scale in the retreading

Ref. Nr.	Length / mm	Division	Verw.	Qty / Pcs
011202	750	mm		1
011203	1000	mm		1
011204	1500	mm		1
011205	1000	mm+Zoll		1
011206	1000	mm		1



### METAL TAPE MEASURE

Ref. Nr.	Length / mm	Division	Verw.	Qty / Pcs
011217	2000	mm	Univ.	1
011211	5000	mm	Univ.	1



011230

### SHORE HARDNESS GAUGE WITH CALIBRATION PART

Ref. Nr.	Description	Division	Qty / Pcs
011230	SHORE hardness gauge	0-99 Shore	1

### HOLLOW KNIFE / CIRCULAR KNIFE SCRAPER

Ref. Nr.	Ø mm	Sizes	Verw.	Qty / Pcs
011401	20	with 6mm shank		1
011402	30	3/8"		1
011403	50	3/8"		1



018180



018180	Ø80 * 90 * 40			1
--------	---------------	--	--	---





**RUBBER KNIFE**

Ref. Nr.	Info	Lenght mm	Qty Pcs.
017050	pointed	150	1
017051	pointed	175	1
017052	pointed	200	1
017054	pointed	250	1
017055	pointed	300	1
018042	offset	--	1

**CUTTING KNIFE**

017090	adjustable	max. 170mm	1
017091	spare blade		10
017100	adjustable	max. 170mm	1
017101	spare blade		10

**FUNNEL KNIFE**

017002	holder for blade		1
017003	spare blade		10

**CUTTING KNIFE**

017140	curved		1
017130	straight	130	1
017110	flexible	100	1
017120	flexible	100	1

**TRIMMING KNIFE**

018010		35	1
018011	spare blade		10
018020		70	1
018021	spare blade		10
018030		110	1
018040		75	1
018041		75	1
018110			

**PLY KNIFE**

Ref. Nr.	Info	Lenght mm	Qty Pcs.
018060	For ply separation		1

**DEBURRING KNIFE**

Art Nr.	Info	Lenght mm	Qty Pcs.
018131	spare blade	80*75	1
018132	holder	500	1

**SCISSORS**

Art Nr.	Info	Lenght mm	Qty Pcs.
011012	straight	200	1
011014	straight	255	1
011007	curved	150	1
011009	curved	187	1

**GRINDSTONES**

Ref. Nr.	Info	Lenght mm	Qty Pcs.
019220	soft square	170*30*20	1

**ELECTRIC KNIFE HEATER**

The knife heater is equipped with a temperature controller and two control laps. It can simultaneously heat two knives with blade sizes up to 12" (300mm). Temperature area: 180° C

Ref. Nr.	Description	Power	Qty Pcs.
018200	Knife Heater	500W	1



**GRINDING ROLLER**

Ref. Nr.:	Size mm	Type	Bearing
016001	13*1,5	Serrated	
016002	25*1,5	Serrated	
016003	38*6	Serrated	
016004	38*1,5	Serrated	
016008	38*4	Serrated	
016012	40*70	Serrated	
016011	40*46	Serrated	
016060	40*18	Serrated	
016050	40*12	Serrated	
016040	40*2,5	Serrated	

**NEEDLE ROLLER**

016120	2-rows*B=8mm	Porcupine	
016090	4-rows, =15mm	Porcupine	
016130	5-rows,B=23mm	Porcupine	
016100	6-rows,B=40mm	Porcupine	
016110	11-rows,B=70mm	Porcupine	

**SPECIAL STITCHERS**

016020	40*46	concave	
016030	60*18	sharp	
016080	60*18	bulge	

**SMOOTH ROLLER**

016150	40*12	smooth	
016070	40*18	smooth	
016010	40*46	smooth	

**SPECIAL METAL GRINDING HEADS**

Ref. Nr.:	Description	Size
011509	Metal grinding head with needels	75mm 1,5*12
011511	Metal grinding ball	39mm 1,5*10

**EXTRUDER**

For quick filling of tire injuries when repairing car, truck and earth mover tires. For processing of extruder line and PR-rubber

Ref. Nr.:	Description	Performance
011479	Extruder Gun	600W

**VAC CLEANER**

017028	Vac cleaner	pneumatic
017029	E-Vac cleaner	1200W / 22V-50HZ

**PATCH HAMMER**

Simplifies installation of large and multilayered patches. Area of application: trucks and earth movers.

016350	Pflasterhammer	
--------	----------------	--

016001







11101



1110



11200



KGE 31 011133



MKE 1-31 011132



KGE 25 011134



011107  
011104  
011112



011205



011114



011109  
+  
011111



011115



011116



011117



**BIAX BUFFING ENGINE / ACCESSORIES**

Professional engine for buffing tires powering flexible shafts for the tire repair. This device is distinguished by long life and high torque.

Ref. Nr.	Description	Rpm	KW	Qty Pcs.
011099	Buffing engine	2800	0,74	1
011100	Movable pedestal	--	--	1
011200	Table stand	--	--	1

**FLEXIBLE SHAFTS FOR BIAX BUFFING ENGINE**

Shafts with core, protective rubber tube without handpiece

Ref. Nr.	Size	Hand piece type	Qty Pcs.
011144	10*1500*19	011134	1
011142	12*2000*23	011133+32	1
11123	10*1500*19	Replacement cores without tubes	1
11120	12*2000*23	Replacement cores without tubes	1

**HAND PIECES**

Ref. Nr.	Description	For core type	Qty Pcs.
011132	Morse taper MK1	12mm	1
011133	Collet chuck 6mm	12mm	1
011134	Collet chuck 6mm	10mm	1

**CASING GRINDERS**

For professional retreading and workshop area. Powered by compressed air. Operating pressure: 6.3 bar.

Ref. Nr.	Description	Areas	Version	Rpm
011107	7070 Adjustable		With quick coupler	0-18000
011104	7075 RE		With quick coupler	4000
011112	7076 Special		With quick coupler	4000
011205	FUJI Pro		With quick coupler	4300

**DRILLS**

Ref. Nr.	Description	Version.	Drive	Rpm
011109	4100 R-rotation	chuck	Compressed air	2200
011111	4550 R/L- rot.	chuck	Compressed air	800
011114	EBS 600	chuck	Electronic	2800

**PNEUMATIC JIG SAW**

Ref. Nr.	Description	Drive	Antrieb	Vib/min
011115	UT 8920 B		Compressed air	9500
011116	Spare steel blades	--	--	--
011117	Rubber saw blade	--	--	--

**QUICKCOUPLER / DRILL CHUCK**

Ref. Nr.	Description
010660	For all Hex sockets 3/8*26
010662	Drill chuck 2-10mm



**PLIERS**

Ref. Nr.	Description	Length mm
018702	Combination plier	200
018715	Side cutter	170
018706	Water pump plier	200
018689	Cord fabric plier	210



**WEIGHT PLIERS**

Ref. Nr.	Description	Length mm
018612	Wheel weight plier	250
018665	Wheel weight plier	250
018613	Wheel weight plier KSK	250
018616	Replacement head KSK	



**STEERING LINK PLIERS**

Ref. Nr.	Area of application	Opening size mm
018688	Passanger/ small truck	14-24
018690	Truck	25-55



**SYNTHETIC HAMMER**

Ref. Nr.	Diameter /mm	Length mm
018722	22	260
018727	27	280



**RUBBER HAMMER**

Ref. Nr.	Size / mm	Weight/gr
----------	-----------	-----------

**VAPORIZER / ACID RESISTANT - BRUSH BOX**

Ref. Nr.	Description	Qty / pcs
011251	Size 1,5 Liter	1



**OILS/ FATS**

Ref. Nr.	Description	Qty / pcs
012395	Squirt oil can	1
010500	Cartridges size 235*53,5	1



**METAL WORKER HAMMER, Forged**

Ref. Nr.	Size	Weight /gr	Rep. handle	Rep. wedge
018791	280 mm	200	001028	010002
018792	320 mm	500	010032	010002
018793	360 mm	1000	010036	010003
018794	380 mm	1500	010038	010003
018795	400 mm	2000	010040	010004



**HEAVY DUTY HAMMER**

Ref. Nr.	Size	Weight /gr	Rep. handle	Rep. wedge
018797	800 mm	5000	10080	10005
018798	800 mm	10000	10080	10005





**TYRE MOUNTING PASTE**

For mounting of tires for every type and size REINHEIMER offers corresponding mounting pastes and creams

- Fast and easy installation
- Chemically neutral to rubber
- High adhesion
- Resistant to spin

Ref. Nr.	Description	Qty.	Consistency
012379	Finish Wax	5-Kg	solid
012389	RP-Fix super car	1-Kg	solid
012491	RP-Fix super car	3-Kg	solid
012390	RP-Fix super car	5-Kg	solid
012391	RP-Fix super car	10-Kg	solid

**UHP - TYRE MOUNTING PASTE**

Is the answer to all known issues in the installation of UHP / RUN FLAT and extreme wide tires. Increases the sliding in the initial phase then provides faster adhesion. Also suitable for truck and agrar tires.

Ref. Nr.	Description	Qty	Consistency
012301	Uni-Breitreifen Paste	5 -Kg	solid
012298	Uni-Breitreifen Paste	10-Kg	solid

**TRUCK TYRE MOUNTING PASTE**

Suitable for long sliding distances, with increased friction effect and drying time, for truck and agrar tires. Very economical in use and chemically neutral to rubber

Ref. Nr.	Description	Qty	Consistency
012372	RP-Fix super truck	5-Kg	solid
012374	RP-Fix super truck	10-Kg	solid
012292	Euro-Tire-Grease	5-Kg	very solid

**TRANSPAFIX**

With the use of TRANSPARFIX, a fully transparent tire mounting paste, one is allowed to apply the crystal clear paste in a clean and streak-free application with unprecedented quality

Ref. Nr.	Description	Qty	Consistency
012312	Transpafix	5-Kg	solid

**AGRAR MOUNT CREAM**

Mount Cream for agrar, earth mover tire molds and solid rubber tires. Use only for tubeless tires.

Ref. Nr.	Description	Qty	Consistency
012375	RP-Fix super EM	5-Kg	soft
012385	RP-Fix super EM	10-Kg	soft
012300	RP-Fix super EM	60-Kg	soft
012299	Creme 35	10-Kg	soft

**TFS TIRE AND TUBE COMPOUND**

With TFS you can quickly and easily solve all of the problems that may occur during installation of a large tire. TFS is the flexible stiff paste for sealing the gap between the tire and rim. It is reusable and can be used also as a tire mounting paste.

Ref. Nr.	Description	Qty	Consistency
012509	TFS Compound	5-Kg	soft
012512	TFS Compound	10Kg	soft



### MOUNTING FLUID

Specially designed for easy installation and removal of truck and earth mover tires. Especially recommended for fixed tire beads.



Ref.Nr.	Description	Contents	Consistency
012914	Pang-Lotion	5-L	liquid
012904	Super Slik	5-L	liquid

### MOUNTING FLUID SUPER GLISS

Diluted 1:6 depending on the area of application. Crawls easily between the tire and rim. Extremely economical in use. For assembly and disassembly suitable.



Ref.Nr.	Description	Contents	Consistency
013001	Super Gliss	5-L	liquid
013002	Super Gliss	10-L	liquid

### MOUNTING FLUID / MOUNTING SPRAY

Especially for the proper assembly of high quality UHP and RUN-FLAT tires. Economical in use. Reduces the risk of clogging pressure sensors in the wheel. Easy to use.



Ref.Nr.	Description	Contents	Consistency
012907	Mounting Fluid	5-L	liquid
012903	Mounting Fluid	10-L	liquid
012900	Fit & Finish	400ml Spray	liquid

### SE-LUBRICANT

Liquid lubricant for assembly of TX / SIT tires.



Ref.Nr.	Description	Contents	Consistency
012251	SE Lubricant	1000ml	liquid

### TIRE TALC

Ref.Nr.	Description	Contents	Consistency
012354	Tire Talc	500gr	powder

### CHALK

Ref.Nr.	Description	Contents Pcs	Sizes	Qty per
011325	Chalk yellow	12 pieces	17,5*90	10
011326	Chalk white	12 pieces	17,5*90	10
011327	Chalk holder	1 piece		
011320	Chalk yellow	12 pieces	13,5*100	8
011322	Chalk white	12 pieces	13,5*100	8
011323	Chalk red	12 pieces	13,5*100	8
011324	Chalk green	12 pieces	13,5*100	8
011321	Chalk holder	1 piece		

### PAINT SPRAYCAN FOR RIMS

Ref.Nr.	Description	Qty	Qty per Carton
012392	Flat code grey	500ml	6 cans
012397	silver	500ml	6 cans
012396	Black dull	500ml	6 cans
012394	Black -shine	500ml	6 cans
012393	Clear colour	400ml	6 cans

### LEAK DETECTOR SPRAY/ CONCENTRATE FLUID

Ref.Nr.	Description	Qty	Qty per Carton
012352	Leak detector spray	400 ml	12 cans
012344	Leak detector concentrate	500ml	1 bottle



Ergibt umgerechnet ca. 60-Dosen Spray!





012373+012383



010011



010010



012356



012360



012388



012243



012019-012021



012024



012018



012022



012402



012364

012358



012361

012362



010088



052480



052481 + 052482



052483



Reifenfarbe 20Kg

012400

**RUST SOLVENT**

Ref. Nr.	Description	Qty Piece	Mastercarton
012353	RP Multirapid	400ml	12 cans
012383	RP Multirapid	5000ml	1 tin

**SILICONSPRAY / EMULSION AS SEPARATING AGENT**

Ref. Nr.	Description	Qty Piece	Mastercarton
012243	Silicon Spray	200ml	6 can
010071	Silicon Emulsion	10000ml	1 tin

**OILS / FATS / COPPER & UNIVERSAL PURPOSE GREASE**

Ref. Nr.	Description	Qty Piece	Mastercarton
010010	Fogging oil for DL tools	1000ml	1 can
012360	Hydraulic oil	1000ml	1 can
012356	Compressor oil	1000ml	1 can
012388	Grease white spray can	400ml	6 cans
012386	CU grease spray can	400ml	6 cans
012387	CU grease tube	100ml	1 can
010011	Grease cartridge	400gr	1 cartridge

**WORK GLOVES**

Ref. Nr.	Description	Size	Qty
012018	Full grain pig leather	9-10	12 pairs
012024	Full grain leather reinforced	9-10	12 pairs
012019	Nitril gloves	8	12 pairs
012020	gloves	9	12 pairs
012021	gloves	10	12 pairs
012022	REIPA-FLEX SUPER TOUCH	9-10	12 pairs

**HAND CLEANING AGENT**

Contains plant oils for skin care. Removes even stubborn dirt. Especially economical in use. Gentle on the skin.

Ref. Nr.	Description	Qty Piece	Mastercarton
012361	REIPA 88H	10 Liter	1 pail
012362	REIPA 88H	5 Liter	1 pail
012402	Dispenser REIPA 88H	1 Stück	1 psc.
012364	REIPA STAR / Dispenserpail	3 Liter	6 pails
012358	REIPA STAR Refillbag	1 Liter	10 bags
012355	Dispenser with holder	1 Stück	1 psc.

**HAND PROTECTION CREAM**

Ref. Nr.	Description	Qty Piece	Mastercarton
010088	PR 88 handprotection cream	1000gr	1 pcs.

**CLEANING RAGS / TOWEL CLOTH**

Ref. Nr.	Description	Qty Piece	Mastercarton
052481	Paper roll 22cm	1	2
052482	Paper roll 38cm*38cm	1	2
052480	Paper roll holder	1	1
052483	Towercloth	1	1

**TYRE PAINT / SOLVENT FREE / WATER DILUTABLE**

Ref. Nr.	Description	Qty Piece	Mastercarton
012403	Tyre paint 470ml	1	12
012400	Tyre paint20kg	1	1

**LP TIRE MARKING MARKER FOR TRACING**

The ideal pen for permanent and indelible marks on rubber. Easy to use, **EVEN FOR THE MARKING ON INSTALLED PATCHES.**

Ref. Nr.	Description	Qty Piece	Mastercarton
012324	LP Marker white	1	12



**TLS TYRE SEALING AGENT / CAR MOTORCYCLE**

TLS can be used as a preventive maintenance product as well as tire repair kit in all cars. The spare wheel is omitted (weight and fuel savings) and the space for the spare wheel can now be used for other purposes. AIR BOX contains a 12V / 10bar compressor which fills the air into the tire again.



Ref. Nr.	Description	Contents	Master carton
012611	TLS MOBIL AIR BOX SET	1 Set	1

**TLS TYRE SEALING AGENT / TRUCK EARTH MOVING AGRICULTURE**

TLS tyre failure protection can be used in all commercial-, Construction-, Earth Mover- and agricultural tyres. Especially suited for small and garden vehicles where maximum speed does not exceed 80 km/h. TLS has a portion of highly closed fibres which prevent time consuming and costly tyre failures. Damages caused by foreign objects up to 14 mm in diameter can be sealed up with TLS in the tread area depending on the workout of the injury.



Ref. Nr.	Description	Contents	Master carton
012610	TLS Tyre Sealing Gel 25 Liter	1 tin	1
012510	TLS Tyre Sealing Gel 10 Liter	1 tin	1
012513	TLS Tyre Sealing Gel 1 Liter	1 tin	12 tins
012511	TLS filling pump 5 / 10 / 25 Liter	1 piece	1

**FIT & FINISH MOUNTING SPRAY**

The development of this product became necessary primarily due to the introduction of new tyre technologies for run-flat tyres. Mounting of tyres with Fit & Finish is superior to conventional mounting pastes. The product is particularly suitable for the mounting of wide base tyres due to its excellent creeping and gliding properties. Fit & Finish can be applied quickly, without problems and physical effort in one operation with only the rotation of the mounting machine. For the application no extra tools are necessary. The mounting spray penetrates easily between rim and tyre, thus enabling a closed pressure resistant gliding film which is very important in demounting. The gliding film is white in the beginning, as an optical indicator showing clearly the sprayed area. Afterwards the product becomes transparent. Fit & Finish offers a good adhesion between tire and rim after the mounting.



Ref. Nr.	Description	Contents	Master carton
012900	Fit & Finish Mounting Spray	1 tin	12

Fit & Finish is officially recommended for TOYOTA wheel assembly.



Ø mm	Round brush	Round-Angle	Wiper	Flat brush	Flat-Angle	mm
20	011302			011305		40
					011317	45
25	011304		012377	011307		53
30		012476		011309		60
40	011310				011318	75
45	011312	012376			011319	100



**BOOT KIT**

**80% elasticity down to -20° C**

Thanks to high elasticity, the cuff is more durable and allows, with the help of the cone assembly, a simple and careful installation even at low temperatures.

**15 mm flat edge and inner lip offset**

This technology allows the adaptability of the cuff with more than 2000 vehicle models.

**RELEASE BY FAMOUS MANUFACTURERS**

High adhesion and sealing strength are kept on all smooth propshaft heads.

**HIGH RESISTANCE**

The cuffs were tested under extreme conditions at a temperature grade of -45° C to +100° C.

Ref. Nr.	Description	Wheel side	Gear side	Ø Drive shaft
011999	DG 2000	100%	84%	55-65mm
012000	DG 3000	100%	84%	65-75mm
012001	DG 3001	100%	84%	75-90mm
012002	DG 4000			

**WHEEL HUBS SET**

A clean wheel hub is the perfect base for a wheel seat and a good operating. With this special grinding set for cleaning the wheel hub, one can quickly and reliably clean the wheel hub. Effective processing time: 10-25 sec per scar. Cleaning discs are interchangeable.

Ref. Nr.	Description	Qty	Content
013502	Set 1 Ø 160mm	1 set	1 Holder / 2 Rep. Discs
013503	Replacement Discs	1 set	3 Rep. Discs

Ref. Nr.	Description	Qty	Content
013600	Set 2 Stud bolts	1 set	2 holders / 6 Rep. Discs
013640	Rep. Discs	1 set	5 small / 5 big Rep. Discs

Ref. Nr.	Description	Qty	Content
013700	Set 3 Ø 200mm	1 set	1 holder / 2 Rep. Discs
013720	Rep. Discs	1 set	2 Rep. Discs

**CLEANING AGENTS GRANULES FOR WHEEL WASHER**

Ref. Nr.	Description	Qty	Content
013230	Granules	1 bag	25 kg
013232	RH Cleaning powder	1 pail	5 Liter

**CLEANING AGENTS FOR HIGH PRESSURE WASHING EQUIPMENT**

Ref. Nr.	Description	Qty	Content
012516	DEGREASER W5000	1 tin	10 Liter

**CLEANING AGENTS FOR KETTY W 2020**

This cleaner sets new standards with its original composition in the cleaning of alloy and steel wheels. The thick and sticky cleaner adheres to the rim and does not run down from the cleansed rim. By the red signal sign one can see exactly which sites were treated thus avoiding a double order. These new features enhance the cleaning power decisively and allow the product to clean every possible soil.

Ref. Nr.	Description	Qty	Content
012501	Brake dust remover	1 tin	5 Liter
012505	Brake dust remover	1 bottle	1 Liter

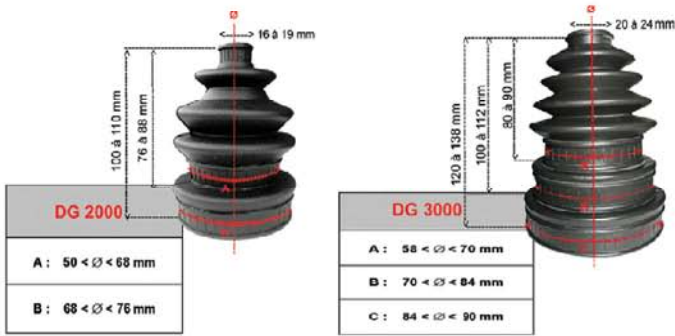



**VALVE CAPS FOR VG8 THREAD**



Ref.Nr.	Description	Qty/Psc.
071311	Valve cap black	100
070994	Valve cap yellow	100
070995	Valve cap blue	100
070996	Valve cap red	100
070997	Valve cap green	100
071997	Valve cap green <i>gastight</i>	100
070998	Valve cap orange	100

**METAL VALVE CAPS FOR VG8 THREAD**



Ref.Nr.	Description	Qty/Psc.
071310	Cap Screwdriver <i>gastight</i>	100
071312	Valve cap metal <i>gastight</i>	100
070999	Valve cap chrome SEK <i>gastight</i>	100
070991	Valve cap chrome small <i>gastight</i>	100
070990	Valve cap chrome type B <i>gastight</i>	100
071313	Valve cap LOGO <i>gastight</i>	100

**METAL VALVE CAPS FOR VG12 THREAD**



Ref.Nr.	Description	Qty/Psc.
078640	Large bore converting cap	10
078605	Valve cap large bore screwdriver	10
078606	Valve cap SEK	10

**VALVE CORES FOR VG5 THREAD**



Ref.Nr.	Description	Qty/Psc.
071332	Valve core short	100
071334	Valve core extra short	100
071330	Valve core long	100
071335	Filter valve core	25

**EM-VALVE CORES / OTR VG8 THREAD**



Ref.Nr.	Description	Qty/Psc.
078632	EM-core short	10
078630	EM-core long	10

**TRACTOR- VALVE CORES**



Ref.Nr.	Description	Qty/Psc.
072342	Air/water valve core old type	10
072341	Air/water valve core new type	10

**VALVE CORE REMOVER**



071370	Valve core remover dual-purpose with magnet	5
071701	Valve screwdriver simple	5

**VALVE CORE REMOVER**



071703	Valve core remover dual-purpose	5
071375	Valve tool including cores for car, truck, EM	1

**VALVE ACCESSORIES**

071360	Valve fishing tool	1
070680	Water filling set	1

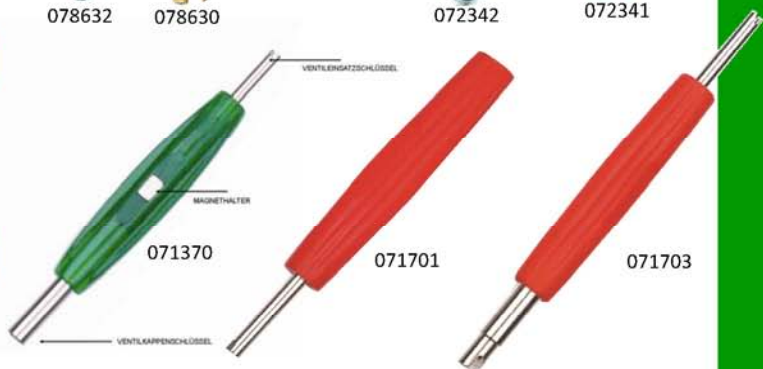





Durchgehendes Hülsgewinde  
Fuß mit Schlitz für Haltewerkzeug  
KST-Scheibe fest montiert  
Dichtung nach ETRTO-Norm  
Mülse passt über die Ventilkappe



072555 072653



072019 072024 072026 072553 072556



Zum einfachen lösen mit Sechskantaufnahme



072558 072557 072018



019010  
019014  
019011



072025



072028 072502 072027 072500

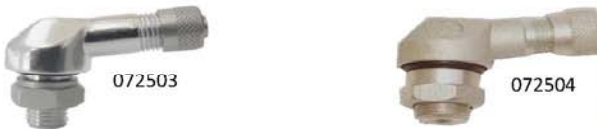

072503 072504

**METAL VALVES QUICK FIT FOR VALVE HOLE 11,3mm**

The universal metal valve for heavy-duty wheels, fast cars, vans, vehicles with high tire pressure and high temperatures.



Ref.Nr.	Description	Length mm	Valve hole Ø	Pressure	Qty/Psc
072553	S25QF-DC / SW 12	47/35	11,3	Up 20bar	20
072555	S25 QF / SW12	42/30	11,3	Up 20bar	20
019010	Special socket wrench SW 12 for easy valve mounting.				

**METAL VALVES FOR VALVE HOLE 11,3mm**



Ref.Nr.	Description	Length mm	Valve hole Ø	Pressure	Qty/Psc
072553	S25AL / SW-11	42	11,3	Up 20bar	20
072556	S25AL-anthracite/ SW-11	42	11,3	Up 20bar	20
019011	Special socket wrench SW 11 for easy valve mounting.				
072024	MS525-S/SW14 short	42	11,3	Up 20bar	20
072026	MS525-L/SW14 long	42	11,3	Up 20bar	20
072019	Valve chrome 42MS/SW14	39	11,3	Up 20bar	20
019014	Special socket wrench SW 14 for easy valve mounting.				

**ALU METAL VALVES FOR VALVE HOLE 11,3mm**



Ref.Nr.	Description	Length mm	Valve hole Ø	Pressure	Qty/Psc
072557	AL-525QF-black/SW-12	42	11,3	Up 20bar	20
072018	AL-525QF-silver/SW-12	42	11,3	Up 20bar	20
072558	AL-525-QF-white/SW12	42	11,3	Up 20bar	20
019010	Special socket wrench SW 12 for easy valve mounting.				

**METAL VALVES FOR VALVE HOLE 15,7mm AND 11,3**



Ref.Nr.	Description	Length mm	Valve hole Ø	Pressure	Qty/Psc
072025	Rim valve 40MS	40	15,7 / 11,3	Up 20bar	4

**METAL VALVES FOR VALVE HOLE 8,3mm**



Ref.Nr.	Description	Length mm	Valve hole Ø	Pressure	Qty/Psc
072027	TR416-SSS/SW11	39	8,3	Up 20bar	10
072028	TR416-SSS-1/SW11	34	8,3	Up 20bar	10

**METAL VALVES FOR MOTORBIKE**



Ref.Nr.	Description	Length mm	Valve hole Ø	Pressure	Qty/Psc
072500	TR430b	34	8,3	Up 20bar	10
072502	TR416	26	8,3	Up 20bar	10
072503	BL25MS 90°	24	8,3	Up 14bar	10
072504	BL25MS 90°	24	11,3	Up 14bar	10

Ref.Nr.	071113	071110	071118	071112	071018
Application					
Function 1	VG-12-outside	VG-10-outside	VG-12-outside	VG-12-outside	VG-8-outside
Function 2	VG-5-inside	VG5-inside	VG-5-inside	VG-5-inside	VG-5-inside
Function 3	Wrench f. EM-Einsätze	Wrench Std - Ventileinsätze	Extractor	Wrench Std - Ventileinsätze	Wrench Std - Ventileinsätze
Function 4	VG8-inside	Extractor f. used inserts	VG8-outside	VG8-outside	Extractor f. used inserts





Our valves are available under the criterion  
Of quality **MADE IN GERMANY**.  
Quality control is ensured due to regular  
Annual follow-up audits.

The proof can be read under:  
[www.tuev-sued.de/Produktzertifikate](http://www.tuev-sued.de/Produktzertifikate)



## SNAP-IN VALVES / TÜV MADE IN GERMANY



Ref.Nr.	Description	TYP un. cap	TYP un. Head + core	TYP metal head	TYP chrome sleeve	Length mm	Valve hole Ø	Pressure max	Qty/Pcs
072413	TR413 / V2.03.1	072613	072513	073413	071000	43	11,3 mm	4,5 bar	100
072414	TR414 / V2.03.2	072614	072514	073414	071001	49	11,3 mm	4,5 bar	100
072418	TR418 / V2.03.4	072618	072518	073418	071003	62	11,3 mm	4,5 bar	100
071400	TR414L / V2.03.8					57	11,3 mm	4,5 bar	100
073309	TR429 / V2.03.9					60	8,8 mm	4,5 bar	10
072415	TR415 / V 2.03.3					43	15,7mm	4,5 bar	20

## HIGH PRESSURE SNAP-IN VALVES

Especially designed valve for trucks and campers with pressure up to 6.9 bar. This valve combines the pressure-carrying capacity of a metal valve with the ease of installation of a snap-in valve. Provides an optimized sealing line and a highly flexible sealing lip to ensure the tightness seal in the rim.



Ref.Nr.	Description	Length mm	Valve hole Ø	Pressure max	Rims thickness	Qty/Pcs
072603	TR 603 HP	43	11,3 mm	6,9 bar	1,8-4mm	100
072604	TR 604 HP	49	11,3 mm	6,9 bar	1,8 - 4mm	100



## ANGLED SNAP-IN VALVES FOR MOTORBIKES



Ref.Nr.	Description	Length mm	Valve hole Ø	Pressure max	Angle	Qty/Pcs
073302	PVR 71	45	11,3	4,5 bar	90°	10
073303	PVR 70	30	11,3	4,5 bar	90°	10
073304	PVR 70 small	30	8,8	4,5 bar	90°	10

## SNAP-IN VALVES FOR MOTORBIKES

Special rubber valves for motorcycles and scooters. All valves are equipped with a up to 300° C heat-resistant valve core. The opening pressure of this core is 50% higher than in standard cores > 4.5 bar.



Ref.Nr.	Description	TYP metal head	TYP un. head	TYP metalhead	TYP chrome sleeve	Length mm	Valve hole Ø	Pressure max	Qty/Pcs
073301	TR412 / V2.03.6	072612	072712	072512	076999	33	11,3	4,5	100



073308	TR438/V2.03.5					35	8,8	4,5	10
--------	---------------	--	--	--	--	----	-----	-----	----

## LEVER FOR SNAP-IN VALVES

Ref.Nr.	Description
071380	Quick Lever
071381	Repl. Protection (071380)
071382	Quick Mount/demounting tool
071367	Lever mounting tool straight
071968	Lever mounting tool angular
071900	Mounting tool synthetic
071901	MOT Lever
078250	Quick Pliers
078267	Replacement jaw KST
078268	Replacement spring

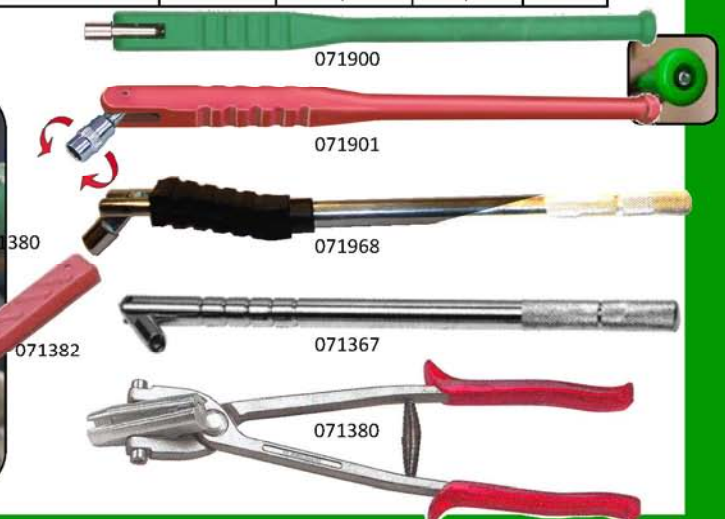



1. Torque wrench 3,4Nm-16 Nm. 1 piece
2. 2 Somet wrenches 11 und 12mm 2 pieces
3. Valve core tool with 0,45Nm 1 piece
4. Rubber grommet pick tool 1 piece
5. Rubber grommet removal tool 1 piece
6. Torque set S7,T10, T15 each 1 piece
7. Wrech set with 1,4 Nm 1 piece



072799



072800

**072800 RDK REPLACEMENT SET**

The practical REINHEIMER replacement parts set enables clear and quick work with valve parts for all major TPMS systems. 424 perfectly matched components ensure a long lasting and reliable operation of the tire pressure monitoring system.

**072799 RDK TOOL BOX**

The TPMS mounting tool set is designed especially for the installation of tire pressure sensors on the valve and rim. The preset torque wrenches offer the recommended standards of the ETRTO and ensure that the components are bolted to the correct torque and the sensors are installed properly.

**RDK SENSORS**

Tire pressure monitoring sensors with metal or rubber valve. Adjustable via ATEQ. Only one sensor for 85% of all vehicles. Free to programm!!



Ref.Nr.	Description	Length mm	Valve hole Ø	Sensor	Qty/Pcs
072804	RDK Metal	42	11,3		4
072803	RDK Rubber	42	11,3		4



072803

072804



073305

073310

073301



072050

075670

**VALVE PATCHES FOR HEAT UP**

Valve patches for heat up in combination with PR rubber / Page 1-11 and HL heating solution.



Ref.Nr.	Description	Length mm	Valve hole Ø	Valve feet Ø	Qty/Pcs
073305	TR13 / V2.01.1	38	11,3	57	10
073301	Spacer sleeve	—	—	—	20
073310	TR15 / V2.01.2	38	15,7	57	10
072050	TR218A / V4.01.1	27	15,7	70	10
075670	Valve plate V3.08.4	10	11,3	70	10

**TRACTOR VALVES**



Ref.Nr.	Description	Length mm	Valve hole Ø	Angle	Qty/Pcs
072056	Wheel nut	--	--	--	20
079618	TR 618A / V5.01.1	50	15,7	straight	4
074010	TR 618 Snap In	50	15,7	straight	4
079221	TR 621A / V5.02.1	78	15,7	115°	4
079222	TR 622A / V5.02.2	118	15,7	90°	4
079223	TR 623A / V5.02.3	60	15,7	115°	4
079700	Blind plug		15,7		10
072341	Insert new		--		10



072341

072056

072056

074010

079222+079221+079223

079700



**VALVES FOR CENTER DROPPED STEEL RIMS / VALVE H. Ø 9,7mm**

Ref.Nr.	Description	Length mm	Angle°	Valve hole Ø	Pressure	Qty/Pcs
079764	41MS	41	straight	9,7mm	up 20bar	10
079273	70MS	70	27°	9,7mm	up 20bar	10
079274	90MS	90	27°	9,7mm	up 20bar	10
079285	100MS	100	27°	9,7mm	up 20bar	10
079290	119MS	119	27°	9,7mm	up 20bar	10
079293	125MS	125	27°	9,7mm	up 20bar	10
070633	58MS	58	45°	9,7mm	up 20bar	10



**VALVES FOR CENTER DROPPED STEEL RIMS/ VALVE H. Ø 15,7mm**

Ref.Nr.	Description	Length mm	Angle°	Valve hole Ø	Pressure	Qty/Pcs
079702	32MS	33	straight	15,7mm	up 20bar	5
079708	42MS	42	straight	15,7mm	up 20bar	5
079715	54MS	54	straight	15,7mm	up 20bar	5
079740	84MS	84	straight	15,7mm	up 20bar	5
079732	89MS	89	90°	15,7mm	up 20bar	5
079745	114MS	114	90°	15,7mm	up 20bar	5
079730	84 MS	84	90°	15,7mm	up 20bar	5



**VALVES FOR CENTER DROPPED ALU. RIMS / VALVE H. Ø 9,7mm**

Ref.Nr.	Description	Length mm	Angle°	Valve hole Ø	Pressure	Qty/Pcs
079765	543D	35	60°	9,7mm	up 20bar	5
078236	543E	35	75°	9,7mm	up 20bar	5
078237	544D	50	60°	9,7mm	up 20bar	5
079768	VF 3-20-5	70	27°	9,7mm	up 20bar	5
079769	40MS-VALCOA	38	straight	9,7mm	up 20bar	5



Our valves are available under the criterion of quality **MADE IN GERMANY**.  
The quality is guaranteed due to regular follow-up audits.

The proof can be read under:  
[www.tuev-sued.de/Produktzertifikate](http://www.tuev-sued.de/Produktzertifikate)

Valve base with Hexagon socket





**FLATBED VALVES FOR VALVE HOLE Ø 15,7mm / STEEL RIM**

Ref.Nr.	Description	ETRTO	Length mm	Thread length	Valve hole Ø	Pressure	Qty/Pcs
079201	40MSF	V3.12.1	40	15	15,7	bis 20 bar	5
079302	40MSF-A	V3.12.1	40	11	15,7	bis 20 bar	5
079035	35-MSF	—	35	—	15,7	bis 20 bar	5
079046	95-MSF	V3.12.2	91	11	15,7	bis 20 bar	5

**TRUCK VALVES SINGLE BEND / STEEL RIM**

Ref.Nr.	Description	ETRTO	Length A	Length B	Angle 1°	Thread length	Valve hole Ø	Qty/Pcs
079133	75MSF-B1	—	28	47	160	11	20,5	5
079132	65MSF-B1	V3.16.1	36	29	150	11	20,5	5
079052	100MSF-B2	V3.13.2	30	29	126	11	15,7	5

**TRUCK VALVES DOUBLE BEND / STEEL RIM**

Ref.Nr.	Description	ETRTO	Length A	Length B	Length C	Angle 1°	Angle 2°	Thread length	Valve hole Ø	Qty/Pcs
079050	95MSF C1	V3.14.2	45	25,5	24,5	147	147	11	15,7	5
079350	95MSF-C1	V3.14.2	45	25,5	24,5	147	147	15	15,7	5
079040	75MSF-C1	V3.14.1	25	25,5	24,5	147	147	11	15,7	5
079058	110MSF-C1	—	25	42	44,5	167	167	11	15,7	5
079161	115MSF-C2	V3.18.1	64	26	24,5	146	146	11	20,5	5
079167	120MSF C1	V3.18.4	51	29	37,5	138	138	11	20,5	5
079169	130MSF-C1	V3.18.2	81	26	24,5	146	146	11	20,5	5
079171	135MSF	V3.18.5	68	29	37,5	138	138	11	20,5	5
079178	140MSF	V3.19.1	33,5	58	46	173	154	11	20,5	5

**SPECIAL FLATBED IN CONNECTION WITH PILOT X TIRES**

Ref.Nr.	Description	ETRTO	Length A	Length B	Angle 1°	Thread length	Valve hole Ø	Qty/Pcs
079702	44,5 MSF	V3.15.1	36	44,5	110	11	20,5	5

For Best Results





**HOSE VALVE SINGLE BEND VG 8 THREAD**

Ref.Nr.	ETRTO	Length A	Height H	Angle 1°	Qty/Psc.
076225	V3.02.5	49,5	20,5	90°	10
076230	V3.02.19	60	20,5	90°	10
076240	V3.02.27	75	20	90°	10
076245	V3.02.08	85	20,5	90°	10
076250	V3.02.9	95	20,5	90°	10
076255	V3.02.26	105	20,5	90°	10
076260	V3.02.10	115	20,5	90°	10
076265	V3.02.11	127	20	90°	10
076275	V3.02.14	140	20,5	90°	10

**HOSE VALVE DOUBLE BEND VG 8 THREAD**

Ref.Nr.	ETRTO	Length A	Length B	Height H	Angle α	Angle β°	Qty/Psc.
076430	V3.04.7	76	44	20	90	154	10
076440	V3.04.22	28	47	20	90	164	10
076445	V3.04.15	42	38,5	20,5	90	120	10
076450	V3.04.23	48	47	20	94	164	10
076455	V3.04.24	58	47	20	94	164	10
076460	V3.04.18	68	47	20	94	164	10
076465	V3.04.25	80	47	20	94	164	10
076475	V3.04.21	83	57	20	94	154	10

**HOSE VALVE TRIPLE BEND VG 8 THREAD**

Ref.Nr.	ETRTO	Length A	Length B	Length C	Height H	Angle α	Angle β	Angle γ	Qty/Psc.
076550	V3.06.13				20				10
076555	V3.06.14	50	13	40	20	94	153	153	10
076560	V3.06.15	60	13	40	20	94	153	153	10
076565	V3.06.16	62	13	50	20	94	153	153	10
076570	V3.06.5	62,5	19,5	49	20,5	90	139	139	10
076575	V3.06.17	75	13	50	20	94	153	153	10

**HOSE VALVE SINGLE BEND VG 12 THREAD**

Ref.Nr.	ETRTO	Length A	Height H	Angle α°	Qty/Psc.
075230	1274A	60	24	90	10
075240	1075A	75	24	90	10
075245	1076A	85	24	90	10
075250	1177A	95	24	90	10
075255	1077A	105	24	90	10
075260	1175A	115	24	90	10
075265	1078A	127	24	90	10
075270	1179A	140	24	90	10
075275	1079A	150	24	90	10

Ref.Nr.	Description	Sizes	Qty/Psc.
075670	Valve base 5670	VG8	10
075713	Rubber ring	24*8*2,5	10
075720	Rubber ring	24*12*2,5	10
075705	Reduction thread	VG8/VG12	10

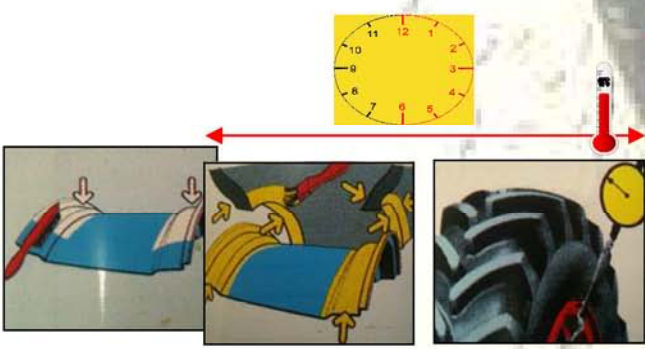
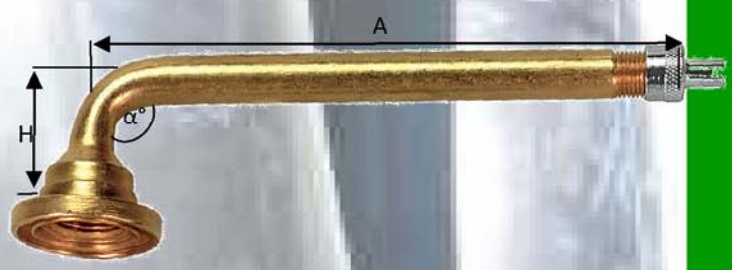
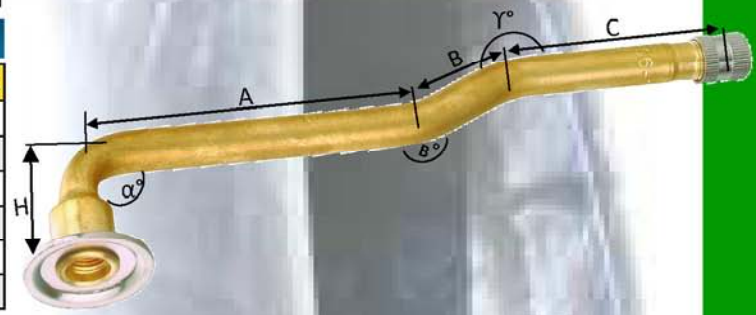
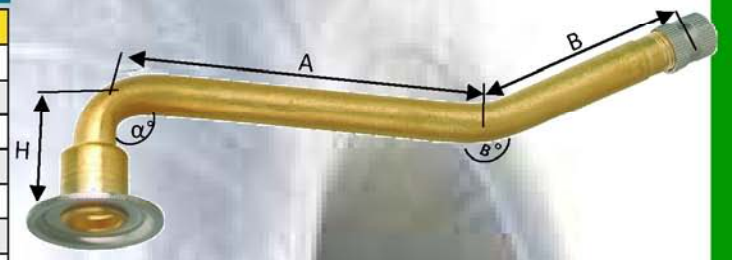
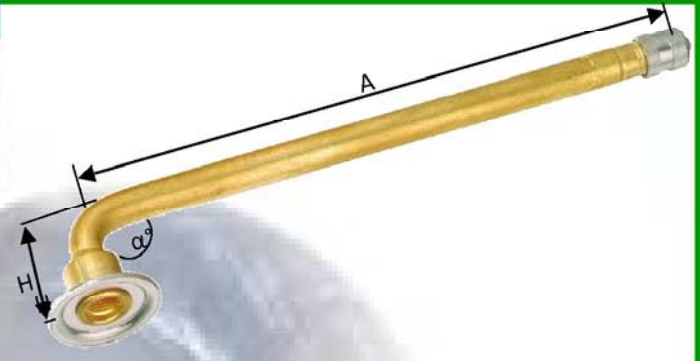

- AGRAR TYRE FIX**  
Sustainably prevents the tire slip on the rim.
- AGRAR TYRE FIX**  
Remains elastic after drying.
- AGRAR TYRE FIX**  
Possesses a good lubricating effect in the initial phase
- AGRAR TYRE FIX**  
Is painted with a brush on the cleaned rim and tire bead seat during the installation.



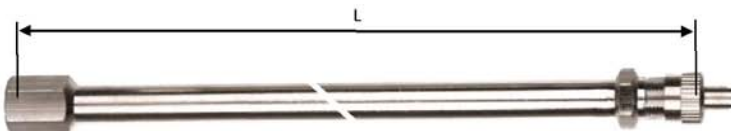
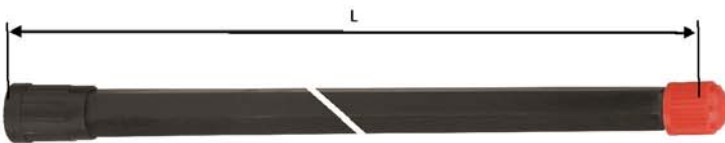
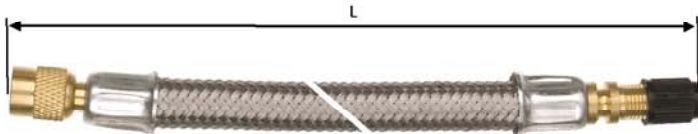
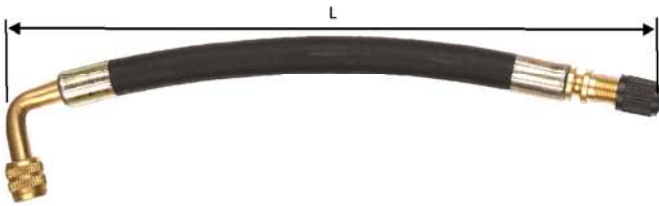
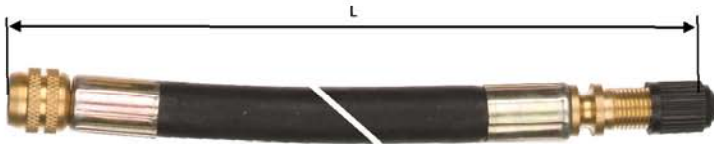

The REINHEIMER check valve cap allows checking the tire pressure and inflating the tire without removing the valve cap:



VALVE EXTENSION VG8 THREAD



Ref.Nr.	Description	L-mm	Type	Qty/Pcs
072100	Extension	85	flexible	10
072101	Extension	105	flexible	10
072102	Extension	115	flexible	10
072103	Extension	125	flexible	10
072104	Extension	140	flexible	10
072105	Extension	180	flexible	10
072106	Extension	210	flexible	10
072107	Extension	270	flexible	10
072108	Extension	335	flexible	10
072059	Angled Extension	210	Flexible/ 90°	10
072062	Angled Extension	280	Flexible/ / 90°	10
072130	Extension	125	flexible / metal	10
072131	Extension	150	flexible / metal	10
072132	Extension	175	flexible / metal	10
072133	Extension	200	flexible / metal	10
072135	Extension	300	flexible / metal	10
072137	Extension	400	flexible / metal	10

HOLDER FOR FLEXIBLE EXTENSIONS



Ref.Nr.	Description	Type	Qty/Pcs
071144	Single holder	metal	10
071431	Double holder	metal	10

VALVE EXTENSION VG8 THREAD

Ref.Nr.	Description	Angle°	Length	Qty/Pcs
072117	Angled Extension	45	30	10
072119	Angled Extension	90	30	10
072120	Angled Extension	67	30	10

VALVE EXTENSION STRAIGHT VG8 Thread



Ref.Nr.	Description	L-mm	Type	Qty/Pcs
072190	Extension	71	plastic	20
072191	Extension	115	plastic	20
072192	Extension	150	plastic	20
072193	Extension	170	plastic	20
072122	Extension	40	metal	10
072123	Extension	60	metal	10
072124	Extension	84	metal	10
072127	Extension	100	metal	10
072121	Extension	24	metal	10
072118	Extension	125	metal	10
072126	Extension	142	metal	10
072128	Extension	170	metal	10

RÜCKSCHLAGVENTILKAPPE VG8 Gewinde



Ref.Nr.	Description	L-mm	Type	Qty/Pcs
071315	Check valve	18	metal	10
072113	Check valve	19	metal	10
072115	Check valve	32	metal	10
072110	Extension	19	plastic	25
072112	Extension	32	plastic	25
072116	Extension	25	plastic	25
072114	Extension	38	plastic	25



**INFLATING GAUGE VG 8**



Ref.Nr.	Description	Type	Qty/Pcs
071088	Inflating gauge	8mm	1
071091	Inflating gauge	8mm	1
071086	Rubber grommet		10
076010	Replacement cap		10

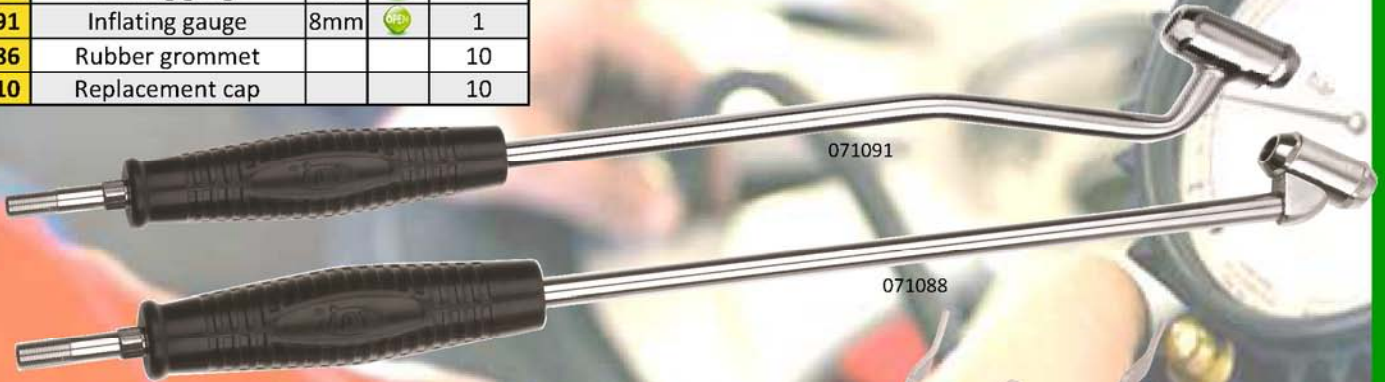

**CLIP-ON AIR CHUCK VG 8**



Ref.Nr.	Description	Type	Qty/Pcs
071068	Clip-on air chuck VG8	6mm	10
070785	Clip-on air chuck VG8	8mm	10
071069	Replacement washer		10
075056	Clip chuck to use for the old type automatic fillers	8mm	5
070773	Clip chuck to use for the old type of automatic fillers	6mm	5
070774	Clip chuck to use for the old type of automatic fillers	8mm	5



**LEVER CLIP-ON VG 8**



Ref.Nr.	Description	Type	Qty/Pcs
071081	Lever Clip-on VG8	6mm	5
071082	Lever Clip-on VG8	8mm	5
072081	Lever Clip-on soud VG8	6mm	5
072082	Lever Clip-on soudVG8	8mm	5
071120	Rep. washer for: 072081 /82		10
071121	Rep. lever pin for: 072081 /82		10



**LEVER CLIP-ON VG 12**



Ref.Nr.	Description	Type	Qty/Pcs
071080	EM-Lever Clip-on VG12	6mm	1
078886	Replacement Grommet		1



**CLIP-ON AIR CHUCK VG 12**



Ref.Nr.	Description	Type	Qty/Pcs
071079	EM-Clip-on VG12	8mm	1

**AIR BLEED CHUCK VG 12**

Ref.Nr.	Description	Type	Qty/Pcs
071430	Air bleed chuck	8mm	1



**ACCESSORIES**

Ref.Nr.	Description	Qty/Pcs
070830	Bicycle adapter 5a/8i	5
070383	Bicycle adapter 5i/8a	5
079990	Air pressure gauge 0,5-4,3-bar	1
079995	Air pressure gauge 0,8-8,3-bar	1





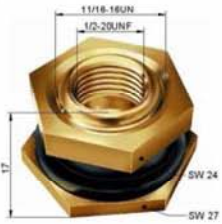

077024



071038

**EM VALVE BASE / SWIVEL TYPE SPUD TUBELESS**



Ref.Nr.	Description	ETRTO	Thread length	Valve hole $\phi$	Pressure	Qty/Pcs
077024	Ventilfuss TRSP2	V5.10.1	17mm	20,5	bis 20 bar	10

**EM VALVE BASE STRAIGHT WITH VG 12 AIR SUPPLY**



Ref.Nr.	Description	ETRTO	Length A	Thread	Qty/Pcs
071038	TR J670	V5.03.1	40,5	1/2-20UNF	5

**EM VALVE BASE ANGLED WITH VG 12 CONNECTION**



Ref.Nr.	Description	ETRTO	Length A	Length B	Angle $\alpha^\circ$	Thread	Qty/Pcs
071263	TR J653		64	27	100°	1/2-20UNF	5
071260	TR J650	V5.04.1	80	27	100°	1/2-20UNF	5
071264	TR J654		80	27	120°	1/2-20UNF	5
071265	TR J655		80	27	106°	1/2-20UNF	5
071267	TR J657		102	27	100°	1/2-20UNF	5
071261	TR J651	V5.04.2	119	32	90°	1/2-20UNF	5
071262	TR J652		140	27	94°	1/2-20UNF	5
071242	TR J4000			27	90°	1/2-20UNF	5

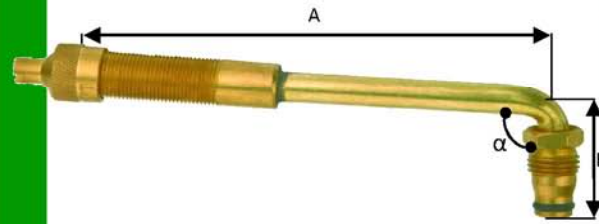

**EM VALVE BASE STRAIGHT**



Ref.Nr.	Description	ETRTO	Length A	Length B	Angle $\alpha^\circ$	Thread	Qty/Pcs
078328	J1014		52		straight	VG 12	5
078245	J1076B		83		80°	VG 12	5
078246	J1076C		73		80°	VG 12	5
078247	J1076D		59		80°	VG 12	5
078248	J1076E		76		80°	VG 12	5
078260	J1175B		108		80°	VG 12	5
078261	J1175C		105		80°	VG 12	5
078262	J1177A					VG12	5
078265	J1078B		118		80°	VG 12	5
078266	J1078C		124		80°	VG 12	5

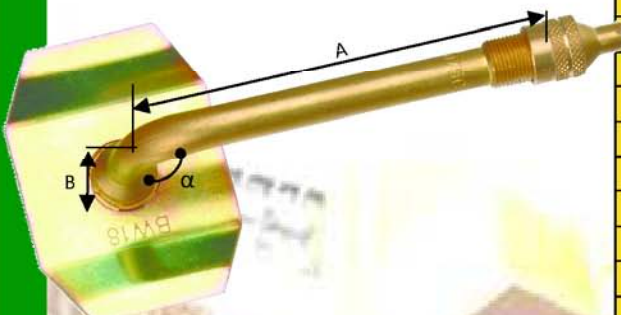

**EM VALVE EXTENSIONS**



Ref.Nr.	Description	L-mm	Type	Qty/Pcs
078675	Extension	104/86	Metal	5
078678	Extension	120/102	Metal	5
078679	Extension	132/114	Metal	5
078680	Extension	145/127	Metal	5
078681	Extension	169/141	Metal	5
078733	Extension	230	Flexible	5
078734	Extension	300	Flexible	5
078735	Extension	360	Flexible	5
078736	Extension	555	Flexible	5
078737	Extension	615	Flexible	5

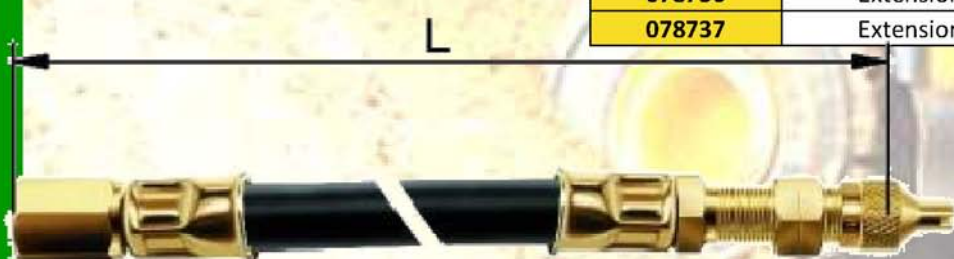



## THE NEW GENERATION OF STEEL CLIP-ON WHEEL WEIGHTS. ECONOMICAL AND RATIONAL !!

With this type of wheel weights we offer exactly what is necessary to eliminate unbalance. The weights are zinc-coated against corrosion and in addition to that have been protected with a resilient and elastic poly-coating. Steel weights are perfect in shape and application.

Box/qty: 5-30g  
each 100-pcs.  
35g up 50-St  
Clips always 100-  
pcs/box

**TYPE 10FE** single piece  
**UNIVERSAL STEEL RIM**



**TYPE 68 FE** single piece  
**UNIVERSAL ALU RIM**



## ZINC WHEEL WEIGHTS WITH INFUSED RETENTION SPRING OR WITH SEPARATE RETENTION SPRING

**TYPE A80Z** single piece



**TYPE 81 Z** single piece  
**FRENCH STEEL RIM**

*Also for DC Sprinter and Ford Transit*



**TYPE 160** single piece  
**OPEL / FORD STEEL RIM**



**TYPE A62Z** single piece  
**UNIVERSAL ALU-RIM**



**TYPE 661** single piece  
**JAPANESE ALU-RIM**



**TYPE 664** single piece  
**FRENCH ALU-RIM**



**TYPE 74Z** two-piece  
**BMW-STEEL.+ALU**  
**VW-STEEL RIM**



**TYPE 280**  
**VW ALU-RIM**



**TYPE 75Z** two-piece  
**DAIMLER STEEL.+ALU**





CLIPS	Ref.Nr.	Combining with weight	Spring type	STEEL	ALU	CAR BRAND
		030174	<b>74Z / 260</b>	74-1		
030274		<b>74Z / 260</b>	74-2			BMW
030374		<b>280</b>	74-3			VOLKSWAGEN
030374		<b>74Z / 260</b>	74-3			VOLKSWAGEN
030175		<b>75Z / 261</b>	75-1			DAIMLER
030275		<b>75Z / 261</b>	75-2			DAIMLER

gr	10FE	A80Z	81 Z	160	68FE	A62Z	661	664	280	75Z	74Z
5gr	038305	039305	037905	031671	038405	039405	036605	036405	032805	030575	030574
10gr	038310	039310	037910	031672	038410	039410	036610	036410	032810	031075	031074
15gr	038315	039315	037915	031673	038415	039415	036615	036415	032815	031575	031574
20gr	038320	039320	037920	031674	038420	039420	036620	036420	032820	032075	032074
25gr	038325	039325	037925	031675	038425	039425	036625	036425	032825	032575	032574
30gr	038330	039330	037930	031676	038430	039430	036630	036430	032830	033075	033074
35gr	038335	039335	037935	031677	038435	039435	036635	036435	032835	033575	033574
40gr	038340	039340	037940	031678	038440	039440	036640	036440	032840	034075	034074
45gr	038345	039345	037945	031679	038445	039445	036645	036445	032845	034575	034574
50gr	038350	039350	037950	031680	038450	039450	036650	036450	032850	035075	035074
55gr	038355	039355	037955	031681	038455	039455	036655	036455	032855	035575	035574
60gr	038360	039360	037960	031682	038460	039460	036660	036460	032860	036075	036074

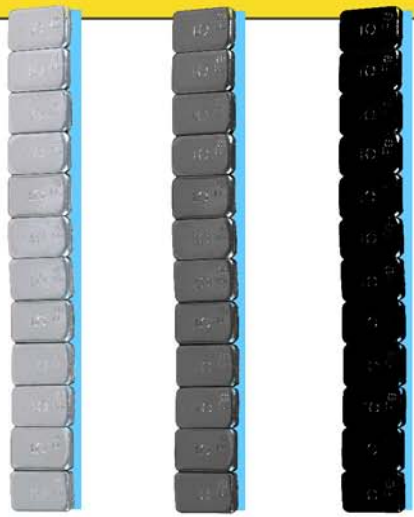

**Lead free STEEL STICK-ON BAR for balancing motor vehicles according to EU-Regulation 2000/53/EG.**

Consisting of steel segments, zinc- and ply-coated against corrosion. Weight is available in bars of each 60 g resp. 30 g or in a rolls of 6 kg or 4.5 kg. Easy cutting through segmented structure because only the bonding foil must be cut through. Advantage: No insulated cut edge, good adaption to rim form, very accurately dimensioned and no special tool is required!

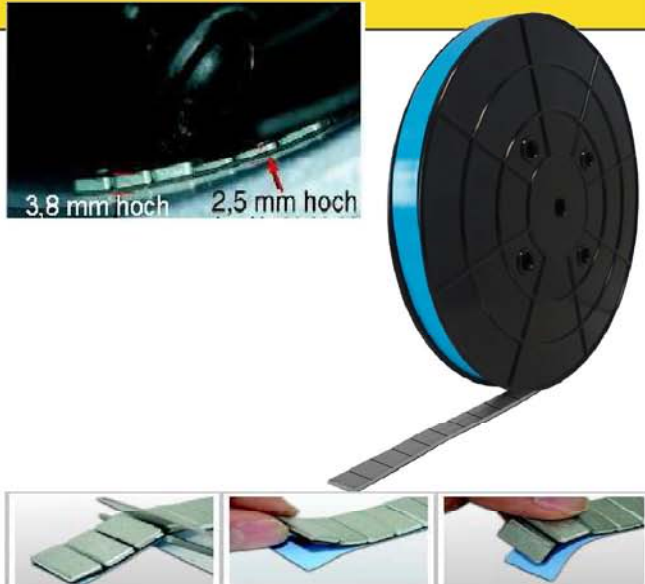
<p><b>Stick-On Weight 60FE</b> height 3,8mm 12*5-Gram bar 60g each</p>	<p><b>Stick-On Weight 30FE</b> height 2,5mm 12*2,5-Gram bar 30g each</p>	<p>037764 Stick-On Weight 60FE on ROLL height 3,8mm 1200*5-Gram 037765 Stick-On Weight 30FE on ROLL height 2,5mm 1800*2,5-Gram 037770 Roll double holder</p>
		
<p>037761      037766      037860</p>	<p>037762</p>	

**ZINC STICK-ON WEIGHT 50-2ZN 50gr / Height 3,8mm / Width 19mm**  
037878 QTY 100 pieces



**ZINC STICK-ON WEIGHT 93-2ZN 45gr / Height 3,8mm / Width 19mm**  
037865 QTY 100 pieces



**ZINC STICK-ON WEIGHT 94-2ZN 30gr Height 2,8mm / Width 19mm**  
037866 QTY 100 pieces



**ZINC STICK-ON WEIGHT TYPE 91-2 Z Height 3,8mm / Width 19mm**

<b>Gewicht</b>	5gr	10gr	15gr	20gr	25gr	30gr	35gr	40gr	45gr	50gr	55gr	60gr
<b>Artnr.</b>	039106	039111	039116	039121	039126	039131	039136	039141	039146	039151	039156	039161





**TRUCK WEIGHT TYPE 53 FOR TUBELESS WHEELS/ 22,5"\*6,75" - 26,5"\*12"**



<b>Weight</b>	50gr	75gr	100gr	150gr	200gr	250gr	300gr	350gr	400gr
<b>Ref.Nr.</b>	035301	035302	035303	035304	035305	035306	035307	035309	035308



**TRUCK WEIGHT TYPE 52 FOR TUBELESS WHEELS/ 22,5"\*6,75"**



<b>Weight</b>	50gr	75gr	100gr	150gr	200gr
<b>Ref.Nr.</b>	035271	035272	035273	035274	035275

**TRUCK STICK-ON WEIGHT TYPE 551 FOR ALU RIMS**



<b>Weight</b>	50gr	75gr	100gr	125gr	150gr	175gr	200gr	250gr	300gr
<b>Ref.Nr.</b>	035510	035511	035512	035513	035514	035515	035516	035517	035518



**TRUCK STICK-ON WEIGHT TYPE 550 FOR ALU RIMS**



<b>Weight</b>	100gr	Stick-on weight with a division of 5*20gr width 15mm * 105mm height 7mm
<b>Ref.Nr.</b>	033038	



**TRUCK BALANCING POWDER**



<b>Weight</b>	8000gr
<b>Ref.Nr.</b>	039002

**WHAT IS QUICK BALANCE 8000 ?**

Quick Balance 8000 is a dry compound with good flow ability, which consists of free flowing Micro-Pearls and other materials. Especially designed for the balancing of truck- and light truck tires.

**HOW DOES QUICK BALANCE 8000 WORK ?**

QUICK BALANCE 8000 works while driving. The centrifugal force causes a equal distribution of the balancing powder on the inner side of the tire. In a not properly balanced tire a „pulling“ is triggered, by the center of the thread or by the differences in the hardness of the tire, which causes the tire to receives vibrations. The loose flow of micro-pearls provide an equal and a countermovement, whereby the position is equalized and the tire remains well balanced.

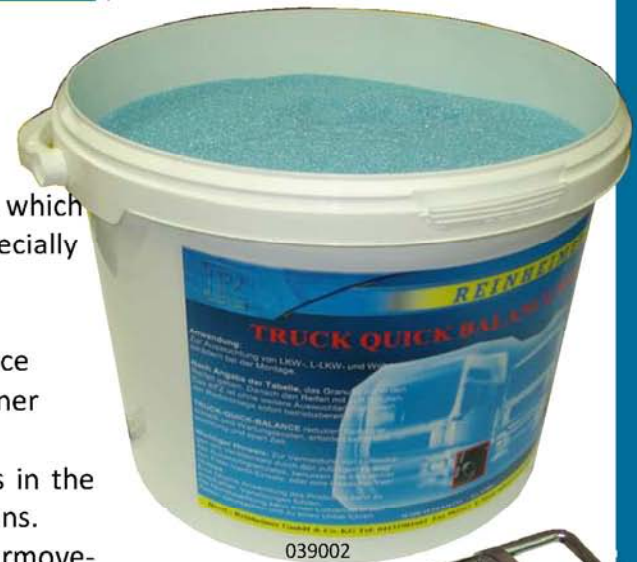



**UNI LEAD WEIGHT MOTORCYCLE / QTY 25 Pieces**

 Universal clip-on spokes weight, easy to deform

<b>Weight</b>	10gr	15gr	20gr	25gr	30gr
<b>Ref.Nr.</b>	035301	035302	035303	035304	035305

**UNI LEAD WEIGHT MOTORCYCLE / QTY 100 Pieces**

 Universal clip-on spokes weight, easy to deform

<b>Weight</b>	10gr	15gr	20gr	25gr	30gr
<b>Ref.Nr.</b>	030010	030015	030020	030025	030030

**SPOKES WEIGHT TYPE 711 / CHROME / 25 QTY**

 Clip-on spokes weight for a thickness of  $\varnothing$  6,2mm

<b>Weight</b>	5gr	10gr	15gr	20gr
<b>Ref.Nr.</b>	037111	037112	037113	037114

**SPOKES WEIGHT TYPE 712 / CHROME / 25 QTY**

 Clip-on spokes weight for a thickness of  $\varnothing$  5,5mm

<b>Weight</b>	5gr	10gr	15gr	20gr
<b>Ref.Nr.</b>	037121	037122	037123	037124

**SPOKES WEIGHT TYPE 713 / CHROME / 25 QTY**

 Clip-on spokes weight for a thickness of  $\varnothing$  5,5mm + 6,2mm

<b>Weight</b>	10gr	15gr	20gr
<b>Ref.Nr.</b>	037131	037132	037133

**STICK-ON WEIGHT K7 / 25 QTY**

 Height 3,5mm / Width 11mm / QTY 25 Pieces

<b>Weight</b>	5gr	10gr	15gr	20gr	25gr	30gr
<b>Ref.Nr.</b>	037141	037142	037146	037143	037145	037144

**MOTORCYCLE STICK-ON WEIGHT KG6-2 / 25 QTY**

 Height 4,7mm / Width 10mm / QTY 25 Pieces

<b>Weight</b>	40gr
<b>Ref.Nr.</b>	037151

**MOTORCYCLE STICK-ON WEIGHT KG6-2 / CHROME**

 Height 4,7mm / Width 10mm / QTY 25 Pieces

<b>Weight</b>	40gr
<b>Ref.Nr.</b>	037152

**STICK-ON WEIGHT SCRAPER / 033112**

**GLUE REMOVER DISC / 033113**

Glue Remover disc to remove tape remains at stick-on weights



Pressing-off pliers for mounting of double wheel weights	Spring-lever for mounting and demounting of double weights	Rim width caliper	Pitch circle diameter measuring tool	RBP Fluid Spezial cleaner for mounting of ALU rims when mounting stick-on weights	Special pliers with KST- protective head for the new generation of wheel weights	Hammer-assistance-tool for mounting of spoke weights
030338	033142	038714	038713	012245	018613	030705
						



**TRUCK MOUNTING IRON**



Ref. Nr.	Description	TYPE	Usage / ° Rims	Length /mm
021571	Truck mounting iron	L	Super Single Tires	900
021572	Truck mounting iron	M	Super Single Tires	900
021573	Truck mounting iron	R	Super Single Tires	900
021535	Truck mounting iron		Drop-Center Rim 21" AS	560
021536	Truck mounting iron		Drop-Center Rim 31" 15°	595
021508	Truck mounting iron	652	Drop-Center Rim	652
021509	Truck mounting iron	653	Drop-Center Rim	653



**HAND ASSEMBLY BOX**

These tools can be used to change tubeless tires with dimensions of 17,5" to 24.5" by hand, even the so-called super singles, single tires with wider tread.



Ref. Nr.	Description
021537	Hand assembly box

**MOUNTING IRON**

Ref. Nr.	Description	Usage	Length /mm
021502	Mounting iron		200
021503	Mounting iron		300

021504	Mounting iron		400
021505	Mounting iron		500
021506	Mounting iron		600
021507	Mounting iron with KST bar		650
021511	KST Rep. bar		--

021530	Tire driver		450
--------	-------------	--	-----

**MOUNTING IRON**

Ref. Nr.	Description	Usage	Socket wrench sizes
021484	Cross wrench		17*19*22 VK 1/2
021446	Cross wrench		24*27*32*VK 3/4

**BEAD HOLDER**

Ref. Nr.	Description	Usage	QTY / Pcs
030190	Bead holder Car		1
030191	Bead holder Car		1
020463	Bead holder Truck		1
020462	Bead holder Truck		1

**MOUNTING PROTECTORS / ASSISTANCE**

Ref. Nr.	Description	Usage	QTY / Pcs
033437	Plastic slide-on protection short		1 set 4 pieces
021510	Plastic slide-on protection long		1 set 4 pieces
033438	Rim protection (half-moon)		1 piece
020151	Truck alu-rim protector		1 piece







020151



**TRUCK RIM PROTECTOR**

This aluminium rims protector is a new way to achieve effective protection of truck and bus alloy wheels from bumps and scratches during assembly. They are simple and universally applicable and require a handle to insert and remove it. The surface is coated.

This rim protector can be used with any truck tire due to various sizes. It is used for most types of rims.



Ref.Nr.	Description	Valve hole Ø	QTY/Pcs
020151	Truck alu-rim protector	281	1



021887

**TRUCK + BUS WHEEL MOUNTING WAGON**

Flexible and ergonomic wheel mounting wagon for changing tires and brake kits, sideways adjustable lifting arms for wheel sizes: Ø270-1300mm

It contains lifting arms with roller bearings for easy adjustment of the wheel / foot operated pump. As well as a safety bracket for fast mounting of the wheel during transport.

Automatically safety switch off.

Ideal for lifting brake drums, tanks and workshop boxes.

Contains two 360° swiveling wheels.



Ref.Nr.	Description	H*W*D	QTY/Pcs
021887	Wheel mounter	1182*989*870	1

**TRUCK + BUS WHEEL MOUNTER**

Problem-free changes of truck, bus and forklift wheels.

Huge time savings.

Adjustable and rotatable mounting bolt.

No damage to the wheel studs.



Ref.Nr.	Description	Weight	QTY/Pcs
021886	Wheel mounter	17kg	1



021886

**AGRAR WHEEL MOUNTING WAGON**

Mechanical wheel mounting wagon for tractors, agrar and construction machines

- Ideal for fast and ergonomic exchange of large wheels– even with profile
- Sideways adjustable roller bearing for wheel sizes of Ø920-2300 mm
- Strong safety strap for quick assurance of the wheel during transport
- Accurate and fast lifting and lowering due to mechanical handwheel
- 4 large and sturdy wheels allow maneuverability
- 3 large and wide roller bearings for easy adjustment of the wheel



Ref.Nr.	Description	H*W*D	QTY/Pcs
021888	Agrar wheel mounter	1360*2380*1160	1



021880



### TIRE TRANSPORT PUSH CART

By activating the handgrips with spring-suspended clamp-mechanism tire or wheel stack can be picked up without strain.

After transport to unloading point, the clamp opens and the stack is relocated or stored away.

Time and energy saving due to a repacking onto a dolly or pushcart is not needed.



Ref.Nr.	Description	H*W*D	QTY/Pcs
021880	Tire transport push cart		1

### TIRE AND TUBE OPENER

Reifenspreizer zur Vorbereitung von Reparatur- und Kontrollarbeiten

Hohe Stabilität und Robustheit / Einfache Handhabung Großer Spreizbereich Auch für RUN-FLAT-REIFEN geeignet

Hält den Schlauch fest und bietet eine glatte Unterlage für die Bearbeitung

Kann PKW- und Motorradreifen spannen / Zur Tischmontage geeignet



Ref.Nr.	Description	H*W*D	QTY/Pcs
025298	Tire and tube opener		1 piece

### CAR TIRE SPREADER

Pneumatic tire spreader for preparing the inspection and repair works.

High stability and robustness / easy handling and high expansion area— suitable for RUN-FLAT TIRES.

Holds the tube and provides a smooth base for processing.

Can stretch car and motorcycle tires / suitable for table mounting.



Ref.Nr.	Description	H*W*D	QTY/Pcs
021209	Tire spreader		1 piece
021213	Reifenspreizer M275 manual		

### AGRAR AND TRUCK TIRE SPREADER

For preparing the inspection and repair of tractor, truck, EM and industrial tires. For changing tubes, bead flaps and all similar work.

With extremely low roll of 200mm.

With a lot of footroom for protection against pinching.

Provides pneumatic lifting of the tire to the desired working height and pneumatic regulating of the spread claw opening.

The unit is designed for one-man operations. Optional can be ordered with 180° swivel and comfortable motor drive.

Halogen lamp included.

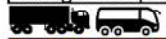

Ref.Nr.	Description	H*W*D	QTY/Pcs
021211	TRUCK TIRE SPREADER S 825		1 piece
021210	TRUCK TIRE SPREADER AB 140	Motor-driven / Swivelable	1 piece

- Working range up to 25"
- Lifting capacity max. 300 Kg
- Lifting cylinder for lifting the thread
- Swivelable 180°
- Motor-driven

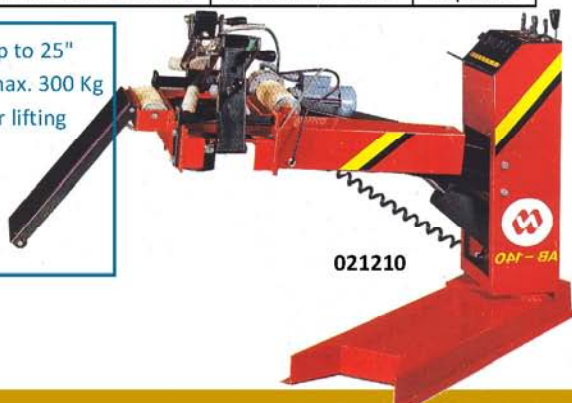

021210



025298



025297



021213



021209



021211





**INFLATING CAGE**

Patented inflating cage from spezial tough steel interrupts the pressure wave and protects against loose fragments. Double Simpex protection layer. Meets all national and international safety and all cages are delivered fully assembled. Contains filling computer.



Ref.Nr.	Description	Specifications	QTY/Pcs
023015	Inflating cage 1018	130 x 150 x 74 cm	1
023016	Inflating cage 1023	130 x 150 x 74 cm	1

**TIRE TEST TANK**

Efficient, safe and convenient testing of cars, trucks and agrar tires. Halogen lamp included. **Available with automatic wheel drive**



Ref.Nr.	Description	Specifications	QTY/Pcs
023013	Tire test tank	92 x 40 cm Korb	1

**TIRE TEST TANK**

Efficient, safe and convenient testing of cars, trucks and agrar tires. Halogen lamp included. **Available with automatic wheel drive**



Ref.Nr.	Description	Specifications	QTY/Pcs
028068	Tire test tank Truck, Agrar, EM	150 x 800 x 680 cm	1
028070	Tire test tank Truck, Agrar, EM	150 x 800 x 680 cm	1



**BLAST FILLER**

For easy mustering of the tire to the bead seat. Blast of air is manually controlled by a ball valve.



Ref.Nr.	Description	Specifications
051926	Blast filler Car + Truck	20 Liter / 10,8kg / 14 bar
051927	Blast filler Truck+EM	40 Liter / 20kg / 9 bar

**BLAST FILLER**

Pump rings allow the filling of all standard tubeless tires. Especially useful in tires that have been deformed by a wrong storage.



Ref.Nr.	Description	Rep. Rubber	
021660	Pump ring car 10"	021677	
021661	Pump ring car "	021678	
021662	Pump ring car 13"	021679	
021659	Pump ring car 13" <small>spezial- Renault, Fiat</small>	021682	
021663	Pump ring car 14"	021680	
021664	Pump ring car 15"	021681	
021656	Pump ring car 16" <small>100mm</small>		
021665	Pump ring truck 16"	021671	
021666	Pump ring truck 17-17,5"	021672	
021667	Pump ring truck 19-19,5"	021673	
021657	Pump ring truck 20"	021674	
021668	Pump ring truck 22-22,5"	021670	
021658	Pump ring truck 24"	021675	
021669	Pump ring truck 24,5"	021676	

021801	Replacement lock	—	—
--------	------------------	---	---





## ELMAX ELECTRIC IMPACT WRENCH

### Save your strength!

With EL-MAX you work in a ergonomical work-position and all heavy work will be taken away from you. Compared with other air-pressure operated machines EL-MAX works quieter and less noisy. Therefore better work-conditions relieve your back, knees and hands.

### A users favourite!







EL-MAX offers a comfortable work-position and high efficiency. All movements are carried out in a ergonomically position and without vibrations. Therefore EL-MAX makes an important contribution to better working conditions. EL-MAX impact wrenches distinguish and convince through proven technique. The mechanics are high and functional. Also economical EL-MAX is a good investment due to an unsurpassed service life.

Ref.Nr.	Description	QTY/Pcs
023002	EL-MAX Impact Wrench	1
023303	Square 1"	1
023302	Square 3/4"	1

Ref.Nr.	Description	QTY/Pcs
Replacement parts for Collmann Impact Wrenches		
027083	VK forged	1
027088	Pin 5,5*45	1
027084	Retention Spring	1
023004	Magurar grip	1
023005	Retention pin	1
023006	Control wire	1
023007	Spring	1
023008	Draw bar	1

## PNEUMATIC SNAP-RING AND TIRE BEAD BREAKER/ AGRAR+EM

Tire demounting equipment for agrar and EM tires. Suitable for 3- and 5-piece rims. Extremely friendly and efficient removal method due to on the vehicle tire disassembling. The robust construction made of aluminium provides this unit about 40% less weight than conventional devices.

Ref.Nr.	Description	Usage	Breaking force
028002	BEAD BREAKER 8002		19800kg
028008	MINI-LEM 8008		4600kg
028022	SHUTTLE 8022		13700kg
028023	MAXI-LEM 8023		4600kg
028560	SUPER LEM 8560		5900 kg
028204	MICRO LEM 8204		2100kg
028287	SNAP RING MOUNTER 8287		—
028037	PNEUMPATIC PUMP 8037		700bar

### Technische Daten:

Höhe:	1045mm
Breite:	620mm
Länge:	1380mm
Arbeitshöhe maximal:	885mm
Arbeitshöhe minimal:	325mm
Gewicht:	59kg
Motorleistung:	1,1KW
Elektrotrieb:	380V / 50Hz
Werkzeugaufnahme:	1" Vierkant
Schlagkraft zum Lösen:	700Nm



023303 + 023302



027084



027083



028023+ 028560



028008

028024



028287



028022



028002





**SOCKET BITS CHROME VANADIUM 1/2"**

WS	Ref.Nr. SHORT 1/2"	Ref.Nr. LONG 1/2"
10mm	027480	
11mm	027481	
12mm	027482	
13mm	027483	
14mm	027484	
15mm	027485	
16mm		027517
17mm	027505	027516
18mm	027504	027510
19mm	027506	027515
20mm	027509	027511
21mm	027486	027514
22mm	027507	027512
24mm	027508	027513
27mm	027487	

**SOCKET EXTENSIONS CHROME VANADIUM**

Ref.Nr.	027499	027501	027500	027502	027530
Square inside	1/2"	1/2"	1/2"	3/4"	3/4"
Length mm	76mm	125mm	248mm	200mm	400mm

**SOCKET BITS CHROME MOLYBDENUM STEEL**

WS	Ref.Nr. SHORT 1/2"	Ref.Nr. LONG 1/2"	Ref.Nr. LONG 1/2" extra thin	Ref.Nr. SHORT 3/4"	Ref.Nr. LONG 3/4"	Ref.Nr. LONG 3/4" extra thin	Ref.Nr. SHORT 1"	Ref.Nr. LONG 1"
10 mm	026010							
11 mm	026011							
13 mm	026013							
14 mm	027001							
15 mm	026015							
17 mm	027002	027010	029020	027020				
18 mm	027003	027015						
19 mm	027004	027012	029021	027021	027037		027050	
21 mm	027005	027011			027034			
22 mm	027006	027013		027022	027035		027051	
23 mm	026023							
24 mm	027007	027014		027023	027040	026905	027052	027065
26 mm	026026						027081	027064
27 mm	027008	027017		027024	027041	026906	027053	027066
28 mm	026028				027038		027062	027063
29 mm	026029							
30 mm	026030	027019		027025	027042	026907	027054	027095
32 mm	026032			027026	027043		027055	027067
33 mm				027027	027033		027056	027096
34 mm								027098
36 mm				027028	027044		027057	027097
38 mm				027079	027046		027058	027068
40 mm							027089	
41 mm					027048		027059	027099
42 mm							027060	027100
46 mm							027061	027101

**EXTENSIONS FOR MACHINES CHROME MOLYBDENUM STEEL**

Ref.Nr.	027071	027072	027073	027074	027075
Square inside	1/2"	3/4"	3/4"	1"	1"
Length mm	150	150	200	200	300

**REDUCTION PIECES**

Ref.Nr.	027076	027077	027078	027079	027080 / Gelenkstück
Square inside	1/2"	3/4"	3/4"	1"	1/2"
Square outside	3/4"	1/2"	1"	3/4"	1/2"





### RIMS OPENING SET

Universal opening set for rim locks, ideal and time-saving if the key is missing. Essential for every tire service business! This saves you time and can provide your customers a professional service without damaging the quality rims. In most cases, the re-ordering of a replacement key is not worth it. Help your customers instantly and do not leave your customers to the competition.

Ref. Nr	Description	QTY
021000	Universal-Rims-Opening-Set	1 piece



021000



### TRANSMISSION TORQUE KEY

Loosing and tightening wheel bolts with one transmission power key. In conjunction with a torque wrench, you can use the targeted and predictable power.

Max. input torque 280NM, output 2940NM

Ref. Nr	Description	Drive	QTY
028570	Transmission torque key	inside 3/4" -outside 1"	1 piece



028570

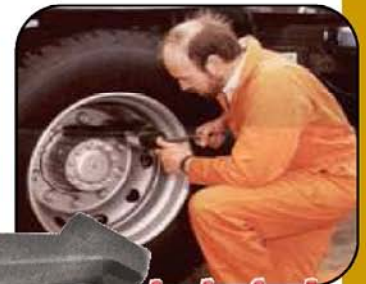

### CAR TORQUE LIMITER

For impact wrenches assure an even tighten of wheel nuts. No rim tension, prevents dynamic unbalance.

Highly recommended for all

Ref. Nr	Description	Drive	QTY
021061	Torque Bar 90 Nm	inside 1/2" -outside 1/2"	1 piece
021062	Torque Bar 100 Nm	inside 1/2" -outside 1/2"	1 piece
021063	Torque Bar 110 Nm	inside 1/2" -outside 1/2"	1 piece
021064	Torque Bar 120 Nm	inside 1/2" -outside 1/2"	1 piece
021065	Torque Bar 135 Nm	inside 1/2" -outside 1/2"	1 piece
021060	Torque Bar Set	inside 1/2" -outside 1/2"	Set



021060

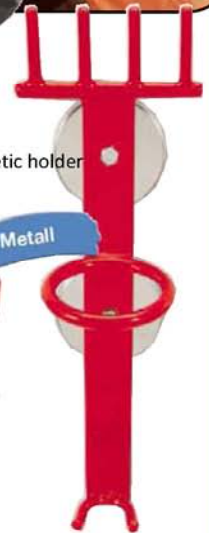

023030 Magnetic holder

### TORQUE WRENCH

Ref. Nr	Description	Drive	Nm	Usage	QTY
026123	HAZET 6122-1CT	1/2"	40-200		1 piece
026121	Rep. ratchet for 025121	1/2"			1 piece
025121	HAZET 5121	1/2"	20-200		1 piece
028573	RAHSOL 8573	1/2"	40-200		1 piece
027542	Rep. Ratchet for 028573	1/2"			1 piece



025121



026123



028573

028569	Truck-torque key	3/4"	140-760		1 piece
028567	Truck-torque key	3/4"	140-760		1 piece
027544	Attachable ratchet	3/4"			1 piece



027544



027542



028569





023015

**CAR IMPACT WRENCH 1/2"**

**950 Nm maximum power**

Professional equipment for tire service and the workshop, quick to use with only one hand.

- Practical one-handed operation of the right-/left- switch with 3 position power regulator for both directions. Thus, the second hand can position a wheel for example.
- \* Solid metal casing for daily professional use.
- \* Powerful dismounting device with low air consumption.
- \* Robust, forged DUOPACT percussion (DP) for high impact force to open difficult fittings.
- \* The impact wrench is lubricated with long-term performance grease.
- \* Good handling due to long handle, suitable for larger hands.



Ref.Nr.	Description	Nm	Weight kg	Air demand	QTY/Pcs
023015	2257	950	2	200	1
023027	Connection set 1/2"	—	—	—	1
103129	Steel spring	—	—	—	1
108695	Pressure ring	—	—	—	1



028418

**COMMERCIAL VEHICLE IMPACT WRENCH 1"**

**2.450 Nm max. torque**

Professional equipment for tire service.

- \* with extended drive spindle 150 mm
- \* ergonomic handle position
- \* Air exhaust lead through the handle
- \* Reduced weight with unchanged high-performance
- \* 3-staged torque adjustment and the right-/left- rotation switch are placed on a shift knob. Which is protected in the rear of the engine cover
- \* with a hammer percussion

**COMMERCIAL VEHICLE IMPACT WRENCH 1"**

Durable 1" commercial vehicle service equipment for trucks and buses

- Massive impact with durable „closed hammer mechanism“ / When releasing with max. 2900 Nm of torque
- Equipped with 3 + 1 position power regulator in a right-/ left- switch.



028419



Ref.Nr.	Description	Nm	Weight kg	Air demand	QTY/Pcs
028418	2426	2450	10,6	370	1
028419	2484	2900	11	370	1
023029	Connection set 1"	—	—	—	1
101879	Steel spring	—	—	—	1
101878	Pressure ring	—	—	—	1



Connection Set



Pressure Ring



Steel Spring



### CENTERING SLEEVE

Optimal centering of truck wheels. Prevents uneven running

Ref. Nr	Hole D/mm	Thread	Truck-Type	Rim
021601	21,0	M18*1,5	Mercedes,Volvo	ST / AL
021602	24,0	M20*1,5	Mercedes,Volvo	ST / AL
021603	26,0	M22*1,5	Mercedes,MAN,Renault, Daf,Iveco	ST / AL
021604	26,0	7/8"11G	Scania	ST / AL



### TRUCK WHEEL NUT

Ref. Nr	Description / Sizes	Form	WS / mm	QTY/Pcs
028245	14*1,5	Sphere bundle	19	10 pieces
028255	18*15 re	Sphere bundle	24	10 pieces
028283	22*1,5re	Sphere bundle	27	10 pieces

028247	14*1,5	Flat bundle	19	10 pieces
028257	18*,15	Flat bundle	24	10 pieces
028263	20*1,5	Flat bundle	27	10 pieces
028275	22*1,5	Flat bundle	27	10 pieces
028276	22*1,5	Flat bundle	32	10 pieces
024901	22*1,5	Flat bundle	30	10 pieces

028231	22*2*25 H	Sphere bundle	32	10 pieces
028234	22*2,5*22	Sphere bundle	32	10 pieces
028304	5004re	Sphere bundle	33	10 pieces
028305	5005 li	Sphere bundle	33	10 pieces

028341	18*1,5	Assembly	27	10 pieces
028342	20*1,5	Assembly	30	10 pieces
028343	22*1,5	Assembly	32	10 pieces

### LIMES RINGS

Ref. Nr	Description / Sizes	QTY/Pcs
028350	C14,5	10 pieces
028351	C16,5-351	10 pieces
028352	C 18,5	10 pieces
028353	C 20,5	10 pieces
028354	C 22,5	10 pieces

### CENTERING RINGS

Ref. Nr	Description / Sizes	QTY/Pcs
028361	14,1*3	10 pieces
028362	18,2*3	10 pieces
028356	20,2*6	10 pieces
028357	22,3*6	10 pieces

### CENTERING SLEEVE

Ref. Nr	Description / Sizes	QTY/Pcs
028308	6*22/25	10 pieces
028309	20*22/25	10 pieces

### PILOT NEEDLES AND PLATES

Ref. Nr	Description / Sizes	QTY/Pcs
028306	Pilot needle	10 pieces
028307	Pilot clamp plate	10 pieces



028309

028308

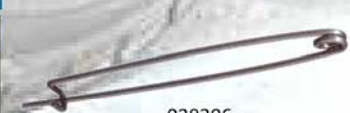

028306



028307





**TIRE WASHING MACHINE KETTY W5000**

**TECHNICAL DATA KETTY W 5000 Art.: 023001**

Case:	Glass fiber-reinforced synthetic material
Brushes:	1*rim outside / 1*rim, inside
Jets:	High pressure pump
Venturi nozzles:	for spezial cleaners
Storage tank:	for spezial cleaners
Drive turn:	2*three-phase motor 0,18 kW
Pump:	Destitute of high pressure pump 120 bar
Pump drive:	Three-phase motor 2,8 KW
Process time:	ca. 90 Sec. depending on the setting
Water usage:	ca. 3-Liter, depending on the setting
Max wheel diameter:	1000 mm
Max whcel width:	400 mm
Source:	Electric 220/380 Volt 50 Hz
Air pressure:	8...15 bar



FILM KETTY WHEEL WASH



**TIRE WASHING MACHINE KETTY W2020**

**TECHNICAL DATA KETTY W 2020 Art.: 022001**

Case:	Glass fiber-reinforced synthetic material
Brushes:	1*rim outside / 1*rim, inside
Jets:	High pressure pump
Drive turn:	Three-phase motor 0,18 kW
Pump:	Destitute of high pressure pump 120 bar
Pump drive:	Three-phase motor 2,8 KW
Process time:	ca. 60 Sek. depending on the setting
Water usage:	ca. 6-Liter, depending on the setting
Max wheel diameter:	800 mm
Max wheel width:	370 mm
Source:	Electric 220/380 Volt 50 Hz
Air pressure:	8...15 bar

Many customers pass through your workshop without them knowing what benefits it brings to wash the tires. Take advantage of this additional sales potential not only in the wheel storage.

**28 YEARS KETTY / The success machine for effective and inexpensive tire care, as is common in good specialist companies today.**

**EFFECTIVE CLEANING**

The KETTY adds it to the cleaning performance with much more expensive systems. Ist effective elements for an optimized cleaning process are:

- \* Nozzles equally distribute the fresh water /
- \* Opposite wheel rotation by drive rollers /
- \* rotatong spezial brushes for inside and outside
- \* the washing result is convincing

**LOW NOISE EXPOSURE**

The KETTY is the quietest machine in ist class (70dB) due to ist design. The noise level in the workshop is kept within the acceptable limits. Especially the nozzles cause no distinct impact sound to the housing.

**FRUGAL IN CONSUMPTION**

The single wheel is washed and rinsed with only 6 liters of water from your home water supply. Arising end waste can be disposed easily according to the local regulations. Optimized drivers guarantee a low energy consumption.

**A ALMOST DRY TIRE**

Compressed air from air supply to the print is used to blow the moisture of tires and rims after finishing the cleaning process. The tire dries off completely after ashort time. If necessary, the tires can be sprayed before washing with detergents.

**ERGONOMIC AFFORDABLE**

The machine can be opened without trouble and loaded with the tire. The loading height is extremely low (about 45 cm) so that the tires can be loaded without any effort.

**STAINLESS SOUNDPROFFING HOUSING**

Aggressive dirt and ´water can not damage the fibreglass reinforced plastic housing. This material is very durable and holds particularly long for a appropriate use.

**NO COLLECTION OF DIRT**

In KETTY the accumulated dirt is transported from the machine immediatly. No service interruption is needed for cleaning or water changes on the machine!

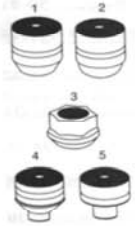

**FELGENSCHLÖSSER**

Ref.Nr.	Shank length	Ball	Cone	Thread	Color	Number
020901	21			12*1,5	silver	901
020902	23			12*1,5	silver	902
020922	24			12*1,5	silver	922
020939	25			12*1,5	black	939
020937	26			14*1,5	silver	937
020930	27			12*1,25	silver	930
020905	28			12*1,5	silver	905
020900	28			12*1,5	silver	900
020928	28			14*1,5	silver	928
020903	28			14*1,5	silver	903
020947	29			12*1,75	silver	947
020944	30			12*1,25	silver	944
020945	30			12*1,5	silver	945
020943	30			14*1,5	silver	943
020948	31			12*1,5	silver	948
020908	32			12*1,5	silver	908
020936	32			12*1,5	silver	936
020931	33			12*1,25	silver	931
020935	33			14*1,5	silver	935
020906	34			14*1,5	silver	906
020942	35			12*1,5	silver	942
020915	38			12*1,25	silver	915
020909	38			12*1,25	silver	909
020904	39			12*1,5	silver	904
020925	41			14*1,5	silver	925
029165	43			12*1,25	silver	9165
020907	43			12*1,5	silver	907
020946	50			12*1,25	silver	946
						
020912	1			12*1,25	silver	912
020910	1			12*1,5	silver	910
020914	1			1/2"	silver	914
020932	2			12*1,5	silver	932
020911	2			14*1,5	silver	911
020940	3			12*1,25	silver	940
020941	3			12*1,5	silver	941
020934	4			12*1,25	silver	934
020938	4			12*1,25	silver	938
020917	4			12*1,5	silver	917
020949	4			12*1,5	silver	949
020939	5			12*1,25	silver	939
020913	5			12*1,25	silver	913

SEAT Ibiza-93, Malag. Rond	930
Ibiz 9/93, Cordoba, Toledo	922
VW all w. 4-Loch	922
Pass, Golf, Corr. VR6, 5Lo.	903
Bus Type4, Sharan	906
Taro	910
VOLVO 240/260	914
440/460/480	930
740/760/940/960	910
850	947
Audi 50/80 Type81	for Rims
Coup. bis 7/84	
Coup. 66 KW	922
80/90, (Typ 85/89B4)	903
100,200,A4,A6,A8, alle	
BMW older	910
3,5,6,7,8 er , Z1,Z3	905
FIAT-all	931
FORD-Fiesta -88	
Esc. Orion -7/90	905
Fiest. ab 89	910
Sierra,Scorp. Capr.,Mond.	
Granada, Probe,Explor.	
Galaxi	906
Maverik	912
MAZDA all	910
MITSUBISHI all	910
Mercedes- Benz	
W107,123,124,126,201	
W202,201,210,R129	904
R129-600SL,	925
W140-280-600SEL	
Geländewagen	
NISSAN all	912
OPEL Asc./Manta A/B	910
Kadett C, Frontera,	
Rekord, Senator A	
Astra, Kadett D/E	902
Cors. Ascona C	
Vectr. Calibra	
Omega, Senator B	
PEUGEOT all	930
RENAULT 5/9/19/21/25/31	930
Clio,Epace,Twingo,Megane	
25 Turbo D/DX/25V6	937





041228



**HYDRAULIC JACKS**

Hydraulic system with hand pump is powerful, compact, versatile and clead. Maximum strength and durability due to double guide. High stability due to large base plate.

Ref. Nr.	Description	To	LS	HS	Usage	Spindle
041001	A2-165	2	165	355		75
041006	A10-220	10	220	530		110
041007	A12-220	12	230	497		110
041009	A15-230	15	230	495		110
041010	A20-240	20	240	505		110
041012	A30-240	30	240	482		100
041020	ATXDX 2,5	3	185	400		—
041021	ATX 5	6	215	500		—
041022	ATG 10-200	10	200	530		68
041026	ATD10-120	10	120	230		Top 65
041025	ATN-10-175	10	175	385		—

Double telescopequipped with horizontally to operate pump, especially appropriate for lifting flat cars, buses etc!

**LIFTING BAGS**

For lifting vehicles, if no jack can be found. Can be driven to lift the vehicleon the wheel or on the body. Ideal for truck breakdown service. Low insertion height of approximately 25 mm.

041095	Lifting Bag	32	32To 53.3 x 63.5 x 2.5 cm	11kg
041195	Lifting Bag	50	50To 73.7 x 73.7 x 2.5 cm	20kg
041295	Lifting Bag	70	70To 86.4 x 86.4 x 2.5 cm	23Kg

**HEAVY DUTY CYLINDER**

For lifting of very heavy vehicles, such as construction machines and wheel loaders.

Ref. Nr.	Description	To	H- Min / cm	H- Max / cm	Weight / kg
048389	Heavy duty Cylinder	55	279	432	17
048390	Heavy duty Cylinder	100	298	451	18
048600	Heavy duty Cylinder	55	260	419	13
048294	Hydraulic pump				10

**TROLLEY JACK**

Very agile and robust lifts. With ergonomic handle.

Ref. Nr.	TYPE	TO	LS	HS	R/H	R/L	B
041229	RF110	3	133	483	160	730	340
041029	2T-C	2	80	500	160	730	340
041031	2T-F	2	90	500	126	950	340
041032	4T-C	4	145	560	200	1270	465
041033	6T-C	6	155	570	210	1395	470
041034	10T-C	10	170	670	280	1700	470
041035	15T-C	15	200	600	325	1790	475

041228	Combination Lift	4	44	730	160	730	460
--------	------------------	---	----	-----	-----	-----	-----

041036	1,5T-HC	1,5	98	800	169	1095	440
041037	2T-HC	2	125	775	195	1340	460
041040	3T-HC	3	130	860	210	1620	460

**REPLACEMENT PARTS**

040000	Rep. Rubber support Compac Jack	
040007	Rep. Rubber support für Jack 041229	
040150	Rep. Steering wheels Nylon	
040153	Rep. Steering wheels Steel	
040629	Spring for guiding handle	
040133	Spring for quick lift device	
040001	Extension	
041039	Rubber air wheels Compac	



Click and Know !!

Table selection of replacement wheels for Compac Jacks



### JACK STANDS

Jack stands made of a very robust structures that can withstand the loads in rough workshop conditions everyday. In addition to that they are made of top quality materials and with the utmost care. Stable stand due to 4 standing legs. The flexible height is adjustable!



Art. Nr.	Tons	TS	HS
041106	1,5	260	450
041108	3	320	530
041109	5	365	590

### PNEUMATIC HYDRAULIC TROLLEY JACKS

Air hydraulic jack with robust construction. Built-in safety valve to prevent overloading. Hard chrome plated piston rod. Practical storage device for accessories available on the lifter. \* Standard equipment includes 2 extensions of 50 and 100 mm.

Art. Nr.	Typ	1 Level	2 Level	3 Level	TS	HS
041088*	AC25-2	25 tons	10 tons		180	375
041090*	ACB25-2	25 tons	10 tons		161	317
041091*	AC-50-2	50 tons	25 tons		220	445
041089*	AC50-3	50 tons	25 tons	10 tons	150	332
041088*	AC 25-10	25 tons	10 tons		162	317
041188	LHH 20	20 tons			260	400

### ACCESSORIES

041093		Extra large saddle pad 145mm diameter
041097		Extra long attachment 250mm

### SHORT LIFTING PLATFORM



Stable and space-saving design suitable for tough workshop use. New, intelligent lifting device for easy overcoming the deadlock in the lowest position. Variable, large reception range of 1600 to 2100 mm. Low height of 100 mm.

041169 2,5 Tons lifting / lift-height 55cm

041171 2,7 Tons lifting / lift-height 55cm

Incl. 4 support arms.

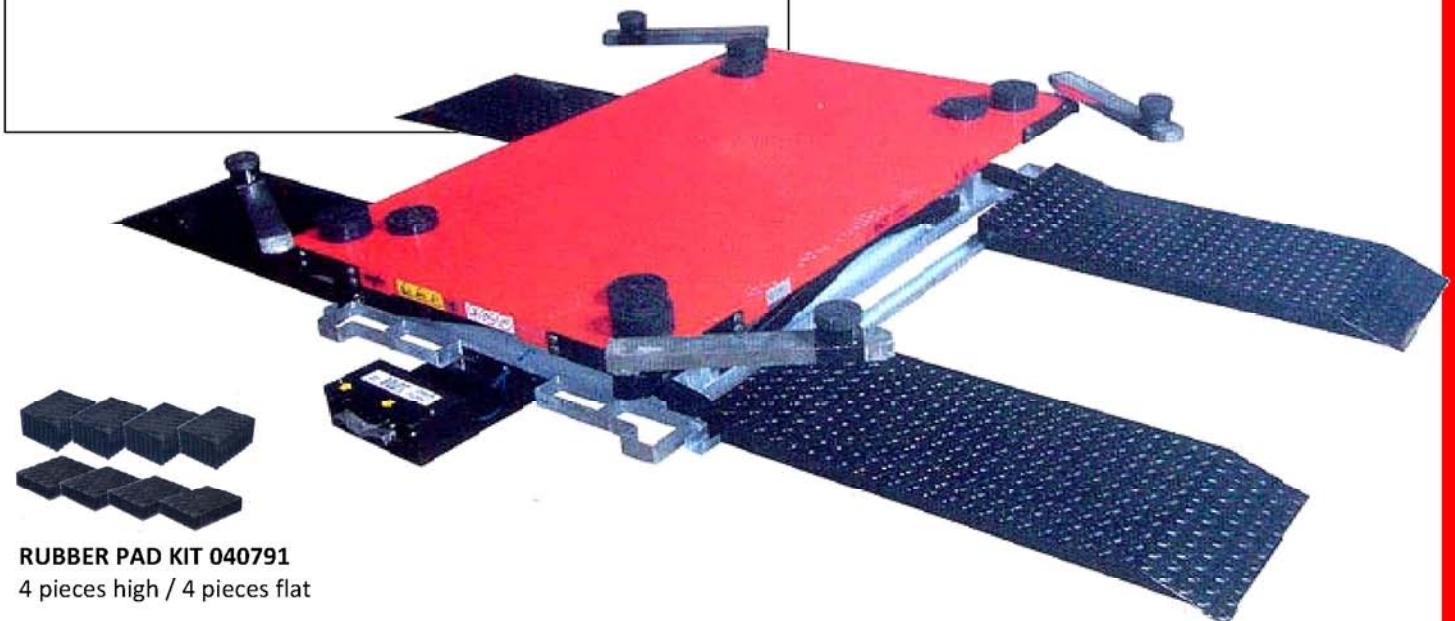

**RUBBER PAD KIT 040791**

4 pieces high / 4 pieces flat







**HAND FILLER**

Hydraulic system with hand pump is powerful, compact, versatile and clean. Maximum strenght and durability due to a double piston guide. High stability due to large base plate.

Ref. Nr.	Description	Connection	Filling span
052905	Handgun RF		0-10 bar
051905	Handgun		0-10bar
051621	Fill computer A Tronic Digital	Clip-on connector	0-12bar

051904	Base filler EWO	Gas-station connector	0-10bar
051907	Base filler EWO Air Fix	Gas-station connector	0-10bar
051923	Rep. Valve		



**INFLATING COMPUTER / 051921**

Inflating computer enables the operator to automatically inflate tire pressure and thereafter to vent atmospheric presure. Before each filling an automatic calibration occurs to compensate for any changes in ambient temperature or humidity. Desired pressure and stop pressure can be adjusted on a 1" LCS display.

**PRESSURE TESTER**

High-precision pressure tester for motorcycle, car, truck and EM tires.

Ref. Nr.	Description	Filling span	Usage
051831	Pressure tester short 45°	0-10 bar	
051832	Pressure tester short straight	0-10 bar	
051833	Pressure tester bent	0-10 bar	
051835	Pressure tester w. hose	0-10 bar	

**NITROGEN GENERATOR**

Professional nitrogen generator with measurement and pressure indicator. Includes modular expansion to adapt to increasing demand quantities by add-on modules. Make your service operation independantly by producing the filling gas for the tire from existing compressed air systems. The device is used in combination with a 70 liters installed by

**Your advantages over gas cylinders:**

- Consistently high gas quality
- Permanently secured gas availability
- Low installation costs
- Minimal operating costs
- All handling costs are ommited
- Security risks that arise when handling gas bottles are ommited

Ref. Nr.	Description	Bar	Production N <sup>2</sup> /h
050452	N <sup>2</sup> Generator FS 4000L	0-10 bar	4000 Liter



### HOSE REEL

Hose reel automatically by a spring force. All hose reel have a locking device. Rationalizes the workplace. Increases safety. Ensures cleanness in the workshop.

Ref. Nr.	Description		Pressure	Media	Length	Hose Ø
055117	Hose reel 1001	1/4	10 bar	Air	15 Meter	8mm
05114	Hose reel 3007	3/8	15 bar	Air	10 Meter	10mm
055115	Hose reel 3009	3/8	15 bar	Air	20 Meter	10mm
055116	Hose reel 9005	1/2	50 bar	Air/Oil	12 Meter	10mm



### AP HOSE

Highly flexible air hose in softtechnology. 3-ply hose from highly flexible PVC with fabric reinforcement. **ORDER BY THE METER!** Complete ring 50 meter !

Ref. Nr.	Ø / inside	Ø / outside	Pressure
052108	6mm	14mm	15 bar
052109	9mm	19mm	15 bar
052110	13mm	23mm	15 bar



### HOSE CLAMPS

Ref. Nr.	Ø / outside	QTY
052108	6mm	10 pieces
052109	9mm	10 pieces
052110	13mm	10 pieces



### HAND CLAMPS

Ref. Nr.	Ø / outside	QTY
052180	13-15mm	10 pieces
052181	15-18mm	10 pieces
052182	17-20mm	10 pieces
052183	20-23mm	10 pieces



### SPIRAL HOSE PLASTIC / NOMINAL WIDTH 8mm

Ref. Nr.	Description		Pressure	Material	Length
055305	Spiral hose + coupling	3/8	15bar	PE / solid	8 Meter
055306	Spiral hose + coupling	1/2	15ba	PE / solid	8 Meter
055307	Spiral hose without coupling	1/4	8bar	PU / soft	6 Meter
055308	Spiral hose without coupling	1/4	8bar	PU / soft	8 Meter

054208 Rep. spring + coupling für Ref.Nr. 055305

054209 Rep. spring + coupling für Ref.Nr. 055306

### ALU HOSE HOLDER

Ref. Nr.	Description
053401	Hose holder small B x T x H: 190 x 70 x 160
053402	Hose holder 'large B x T x H: 250 x 100 x 210



### AIR PRESSURE GUN

Ref. Nr.	Description
054190	Air pressure gun made of ALU cast



### HAND LAMP

Ref. Nr.	Description
055302	LED hand lamp inkc. charger
055301	Hand lamp 8W / 220V





Ref.No.	Description	Size	Connection
<b>COUPLING WITH OUTSIDE THREAD</b>			
054261	Coupling	1/4	Outside thread
054262	Coupling	3/8	Outside thread
054263	Coupling	1/2	Outside thread



Ref.No.	Description	Size	Connection
<b>COUPLING WITH INSIDE THREAD</b>			
054266	Coupling	1/4	Inside thread
054267	Coupling	3/8	Inside thread
054268	Coupling	1/2	Inside thread



Ref.No.	Description	Size	Connection
<b>COUPLING WITH HOSE CONNECTOR</b>			
054271	Coupling	6mm	Hose connection
054272	Coupling	9mm	Hose connection
054273	Coupling	13mm	Hose connection



Ref.No.	Description	Size	Connection
<b>SOCKET WITH INSIDE THREAD</b>			
054283	Socket	1/4	Inside thread
054284	Socket	3/8	Inside thread
054285	Socket	1/2	Inside thread



Ref.No.	Description	Size	Connection
<b>SOCKET WITH OUTSIDE THREAD</b>			
054255	Socket	1/8	Outside thread
054281	Socket	1/4	Outside thread
054282	Socket	3/8	Outside thread



Ref.No.	Description	Size	Connection
<b>SOCKET WITH HOSE CONNECTOR</b>			
054277	Stecktülle	6mm	Schlauchanschluß
054278	Stecktülle	9mm	Schlauchanschluß
054279	Stecktülle	13mm	Schlauchanschluß



Ref.No.	Description	Size	Connection
<b>TRUCK COUPLING</b>			
054211	TRUCK Coupling	1/2	Inside thread
054210	TRUCK Coupling	1/2	Outside thread

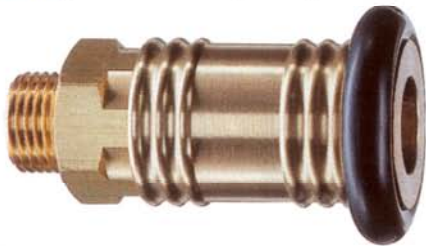

Ref.No.	Description	Size	Connection
<b>TRUCK SOCKET</b>			
054220	TRUCK SOCKET	1/2	Outside thread
054221	TRUCK SOCKET	13mm	Hose connection



Ref.No.	Description	Size	Connection
<b>OUTSIDE THREAD WITH HOSE CONNECTION</b>			
054317	Outside thread	3/8	Hose Connection 13mm
054320	Outside thread	1/2	Hose Connection 13mm
054315	Outside thread	3/8	Hose Connection 6 mm
054316	Outside thread	3/8	Hose Connection 9 mm
054314	Outside thread	1/4	Hose Connection 9 mm
053313	Outside thread	1/4	Hose Connection 6 mm



Ref.No.	Description	outside	inside
<b>REDUCING BUSHING</b>			
054352	Reducing bushing	1/2	3/8
054351	Reducing bushing	3/8	1/4
054350	Reducing bushing	1/4	1/8



Ref.No.	Description	outside	inside
<b>DUAL NIPPLE</b>			
054347	Dual nipple	1/2	1/2
054346	Dual nipple	3/8	3/8
054345	Dual nipple	1/4	1/4
054344	Dual nipple	1/8	1/8



Ref.No.	Description	outside	inside
<b>REDUCING NIPPLE</b>			
054342	Reducing nipple	3/8	1/2
054341	Reducing nipple	1/4	3/8
054340	Reducing nipple	1/8	1/4
054343	Reducing nipple	1/2	3/4



Ref.No.	Description	Size	Connection
<b>BALL VALVE</b>			
054105	Ball valve	3/8	Inside thread
054104	Ball valve	1/4	Inside thread
054106	Ball valve	1/2	Inside thread
054107	Ball valve	3/4	Inside thread



Ref.No.	Description	Size	Connection
<b>HOSE CONNECTOR</b>			
054325	Hose connector	6mm	Hose connection
054327	Hose connector	9mm	Hose connection
054326	Hose connector	6/9mm	Hose connection



Ref.No.	Description	Size	Connection
<b>AIR MAINFOLD</b>			
054265	2 Air manifold	3/8	Inside thread
054264	2 Air manifold	1/2	Inside thread
054270	3 Air manifold	3/8	Inside thread



052209 Teflon tape



052211 Sealing fluid for air connection



### SERVICE UNITS

Ref.No.	Pos	Description	Pressure
054291		Wartungseinheit	0-16 bar
054047		Filterdruckregler	0-16 bar
054293	1	Filtertrockner	0-16 bar
054046	2	Druckminderer	
054048	3	Nebler Öler	
054049	4	Halterung f. Wartungseinheit	
054050	5	Halterung für Druckregler	



### MOTOR COMPRESSOR

Independent work from the power grid, you can work with the gasoline-powered Honda generator. For applications with very high air demand by powerful Ingersolrand aggregate. Fully automatic operation with speed regulation. 15-year warranty on air-tank against corrosion. Fully equipped with lubricator and filter pressure reducer. Two pressure gauges for tank and working pressure. All units with electric start feature. Easily accessible condensate drain cock

Ref.No.	Description	Fuel	Pressure	Weight
056209	AIR JET 2020	Benzin	0-12 bar	192
056210	AIR JET 2030	Diesel	0-12 bar	192
DATA	Effective air power 1250Liter / Dimensions H* W*D 940 * 1130 * 580			



### POWERSTATIONS

Under harsh conditions each Powerstation guarantees a ultimate and a reliable performance. With the robust power stations of REINHEIMER you can work independent of electricity and air. Whether normal 220V AC or 380AC with air for cars or EM tyres with the EP2050 / EP2015 you are always well equipped. Steel bushings ensure long life, protection separations provide security and compliance with all regulations this is a matter of course. Selected components guarantee a long use of the equipment

#### SPECIFICATIONS:

- power 220/380V
- Air capacity 1250 liters effectively
- Dimensions 1680 \* 630 \* 1150
- weight 320kg

Ref.No.	Description	Fuel	Pressure	Power
057107	Group Air 2015	Benzin	0-12 bar	8,5KW
057101	Group Air 2050	Diesel	0-12 bar	12,5KW





## HISTORY OF REINHEIMER

The history of Reinheimer is closely related to the trademark PANG, which was registered in 1926. A few years before this date, on September 1<sup>st</sup> 1919, Mr. Fritz Friedrich HESSELBEIN had started a chemical factory in Hamburg/Germany, where he further developed his invention of self-vulcanising Tyre- and Tube Repairmaterials. Nowadays there are hardly any tyre dealers and tyre retreaders in the international market who are not familiar with this complete program of quality material.

On July 1<sup>st</sup> 1935 Philip Reinheimer, a master of mechanics, established a factory to produce technical equipment and tools for the tyre industry. Shortly after, to meet increasing demands, Reinheimer adjusted to the requirements of the market and added, next to his own tools, equipment and items of other manufacturers. Out of a master workshop, a trading company was established with its own production, providing customer service and expert advice.

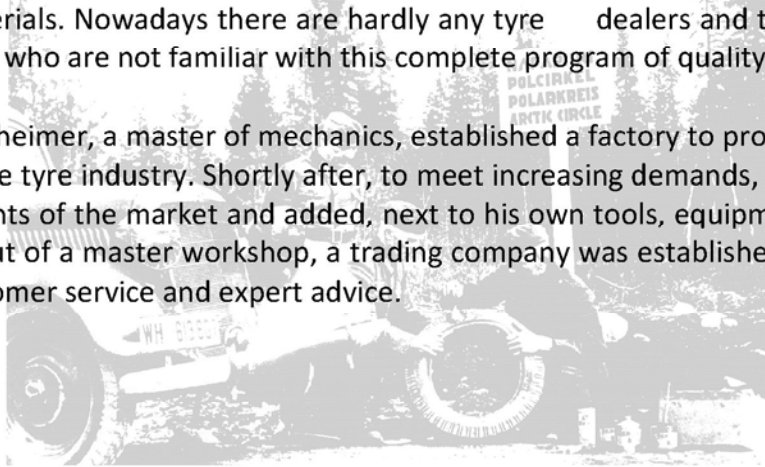

## REINHEIMER THEN:

Because of high quality and usefulness of their special tools and vulcanising repair materials, the two companies soon combined their activities and became well known beyond the borders of Germany and Europe.

Especially PANG pressed forward into the American market and established a close cooperation with the Los Angeles based manufacturer of vulcanising materials TRUFLEX Rubber Products Co.

Philip Reinheimer opened other subsidiaries in Hamburg and Salzburg/Austria for distribution. In 1992 the range of CHEMOTEK items was added. With this production of different chemical materials to the tyre trade and other crafts, a long-time gap was filled. It has also become a successful part of our international business.

In the age of globalisation the German company PANG INDUSTRIES and REINHEIMER fused in 1992.

## REINHEIMER TODAY:

Meanwhile, due to globalisation of markets, the name REINHEIMER has become a well known trade name. Worldwide business contacts and supply contracts with several production facilities are a guaranty for our customers to be supplied with quality products on the highest level. As manufacturer of products MADE IN GERMANY and TÜV-tested imported merchandise we are delivering today a full programm of selected articles to specialized traders and the industry.

We are using our experience of over 80 years in tyre technology to keep up to date with the requirements of the market. By using the motto:

***“ We offer what others would like to have”***

we want to give customers confidence and convince them to have trust in our competence and reliability in servicing them.

In addition to reliable deliveries with premium quality material, we are also offering our customers instructions and training through our expert application technicians.



**THE PROFESSIONAL'S CHOICE  
FOR TYRE REPAIR  
SINCE 1919**